

Thule Pack 'n Pedal Basket 100050

> Instructions

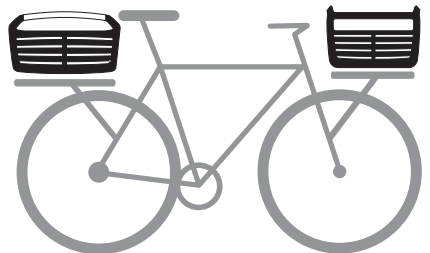
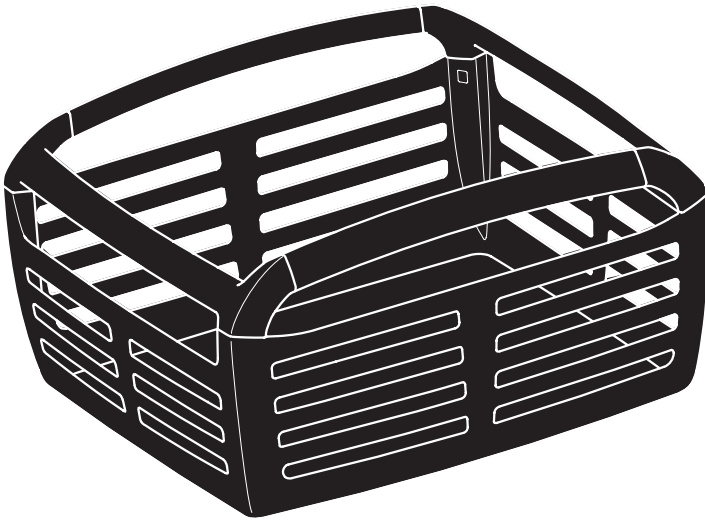

100050

C.20140305
501-7917-01

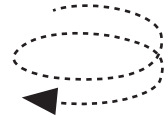
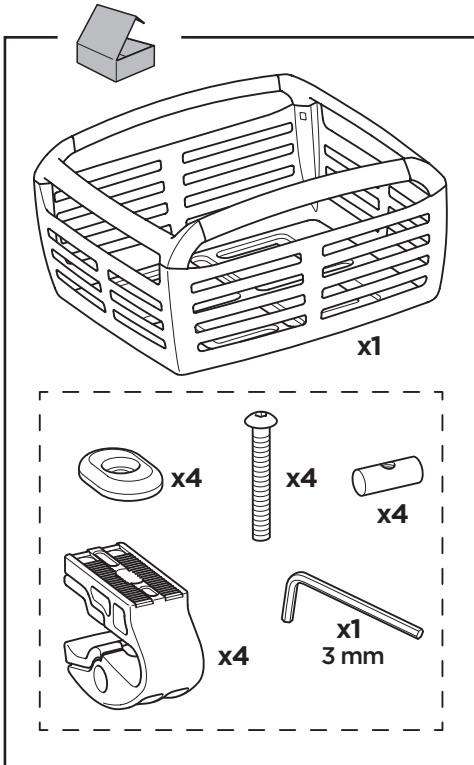
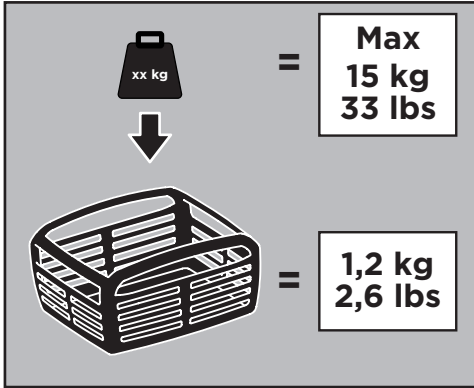
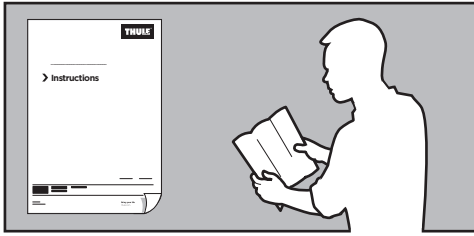

- EN** Only a few turns
- DE** Nur wenige Umdrehungen
- FR** Quelques tours uniquement
- NL** Slechts enkele slagen
- IT** Solo qualche giro
- ES** Sólo algunas vueltas
- PT** Noções básicas
- SV** Endast några varv
- DK** Kun nogle få omgange
- NE** Bare noen få omdreininger
- FI** Vain muutama kierros
- ET** Ainult mõni pööre
- LV** Tikai daži apgriezieni
- LT** Tik keli pasukimai
- PL** Wystarczy kilka obrotów
- RU** Только несколько оборотов
- UK** Лише декілька обертів
- BG** Само няколко завъртания
- CS** Pouze několik otáček
- SK** Len niekoľko otáčok
- SL** Le nekaj obratov
- HR/BiH** Samo nekoliko okreta
- RO** Doar câteva rotiri
- HU** Csak néhány fordítás
- EL** Μόνο λίγες περιστροφές
- TR** Yalnızca birkaç tur

AR بعض دورات فقط
HE רק מספר סיבובים

- ZH** 仅几圈
- JA** 2～3回転のみ
- KO** 몇 번만 돌리면 됨
- TH** เพียงสองสามรอบ

5 years warranty
Jahre Garantie
ans de garantie
años de garantía

i

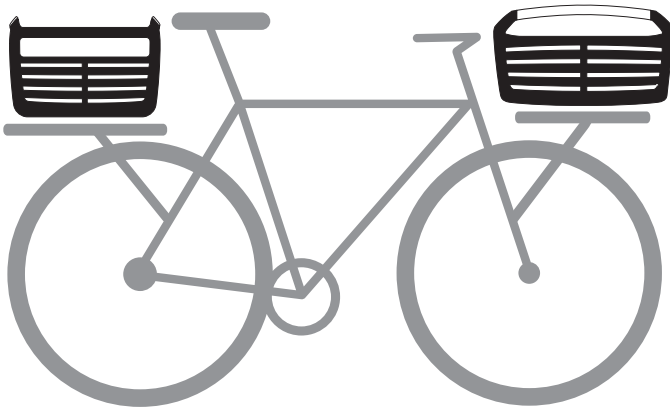
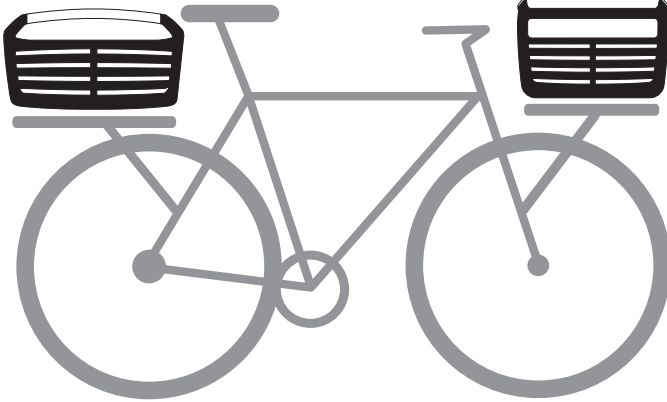

1

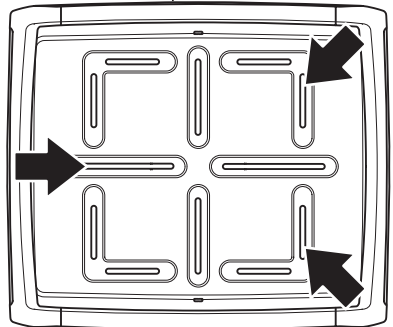
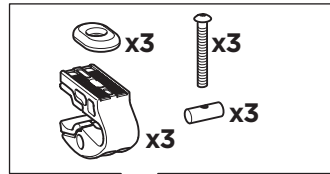
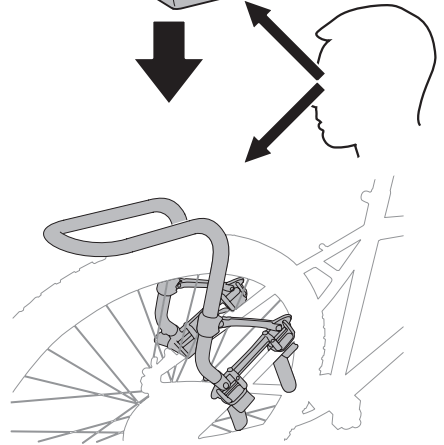
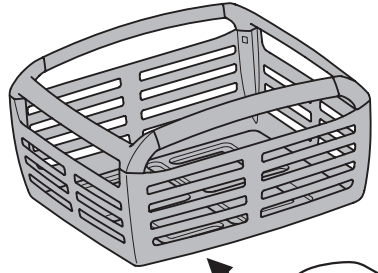
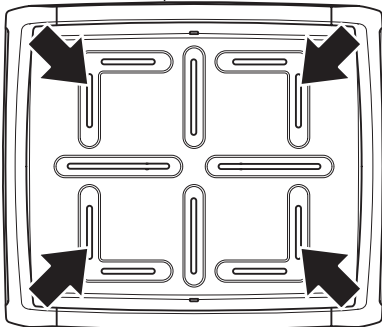
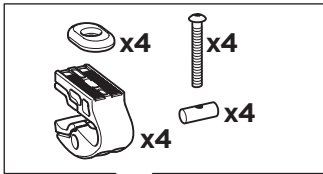
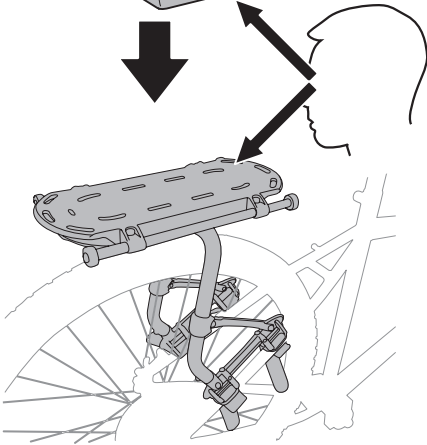
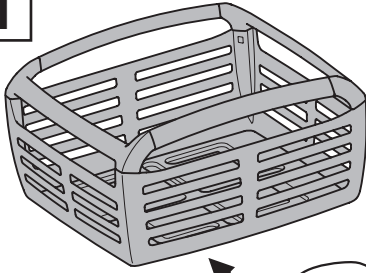

1

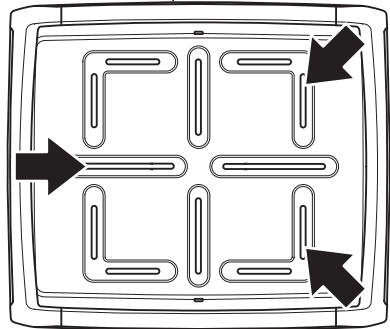
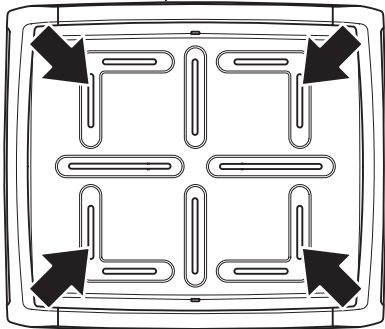
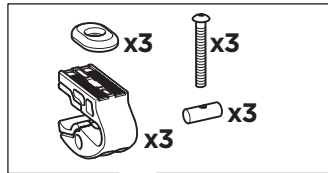
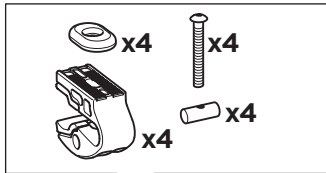
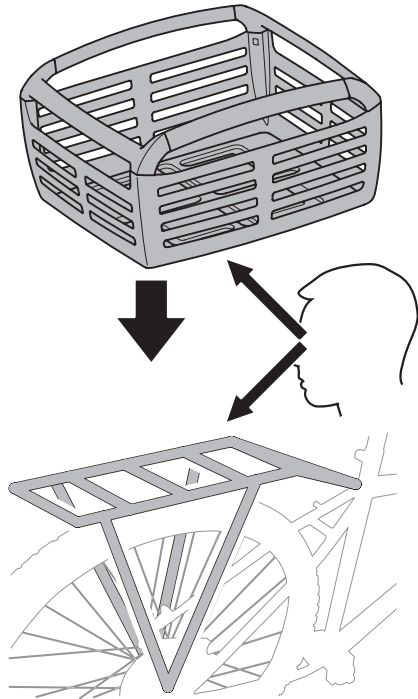

2

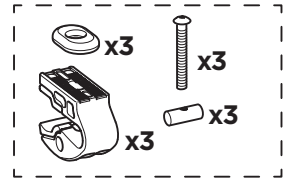
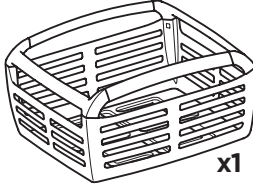
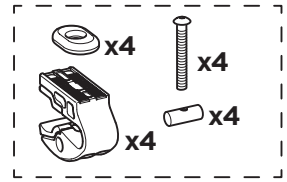
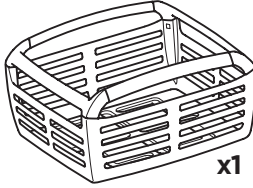
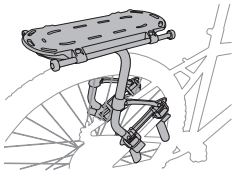

i * 2-3 ↻

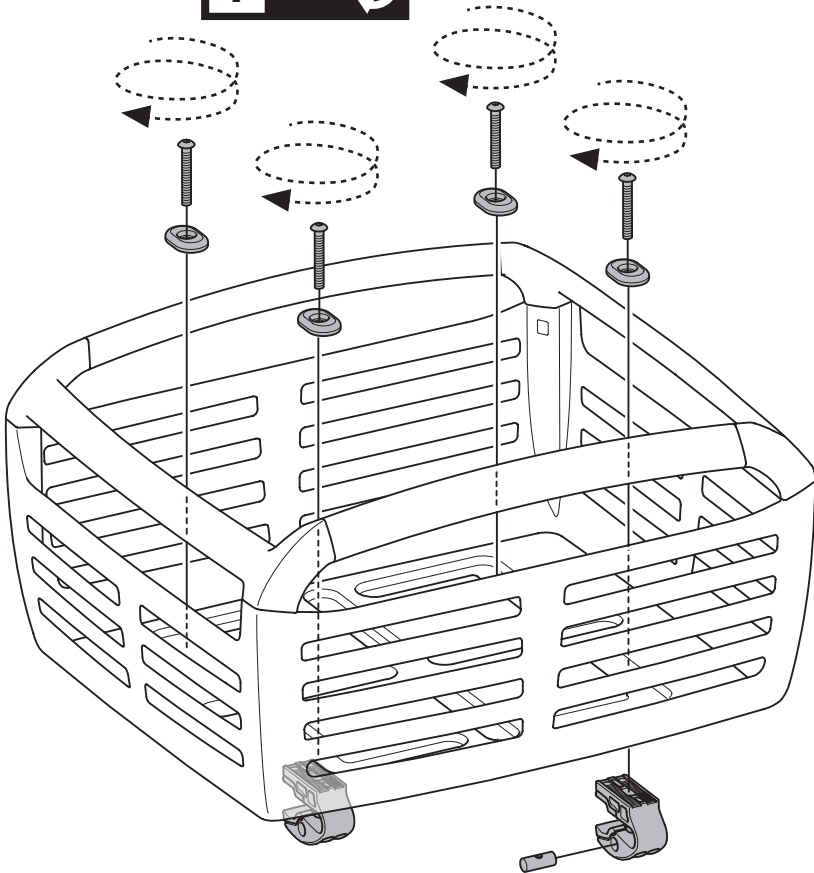

3

A

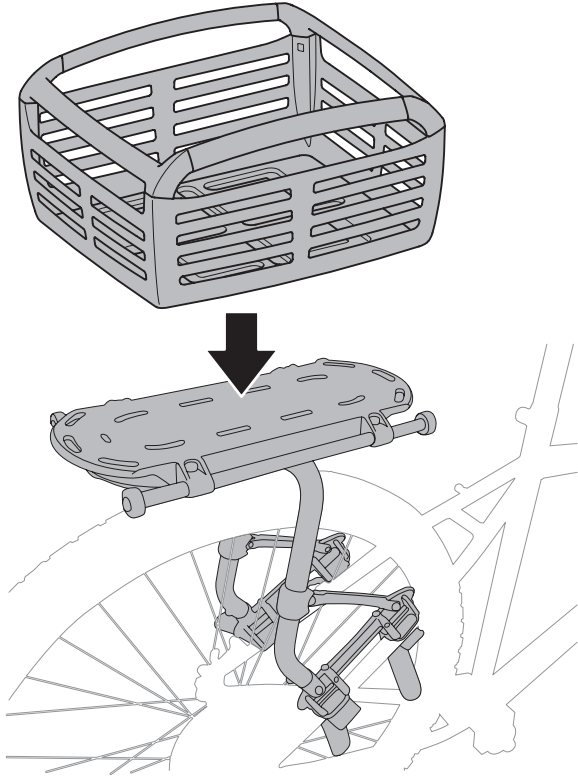

B

