

# YAKIMA

# FullBack™

# US

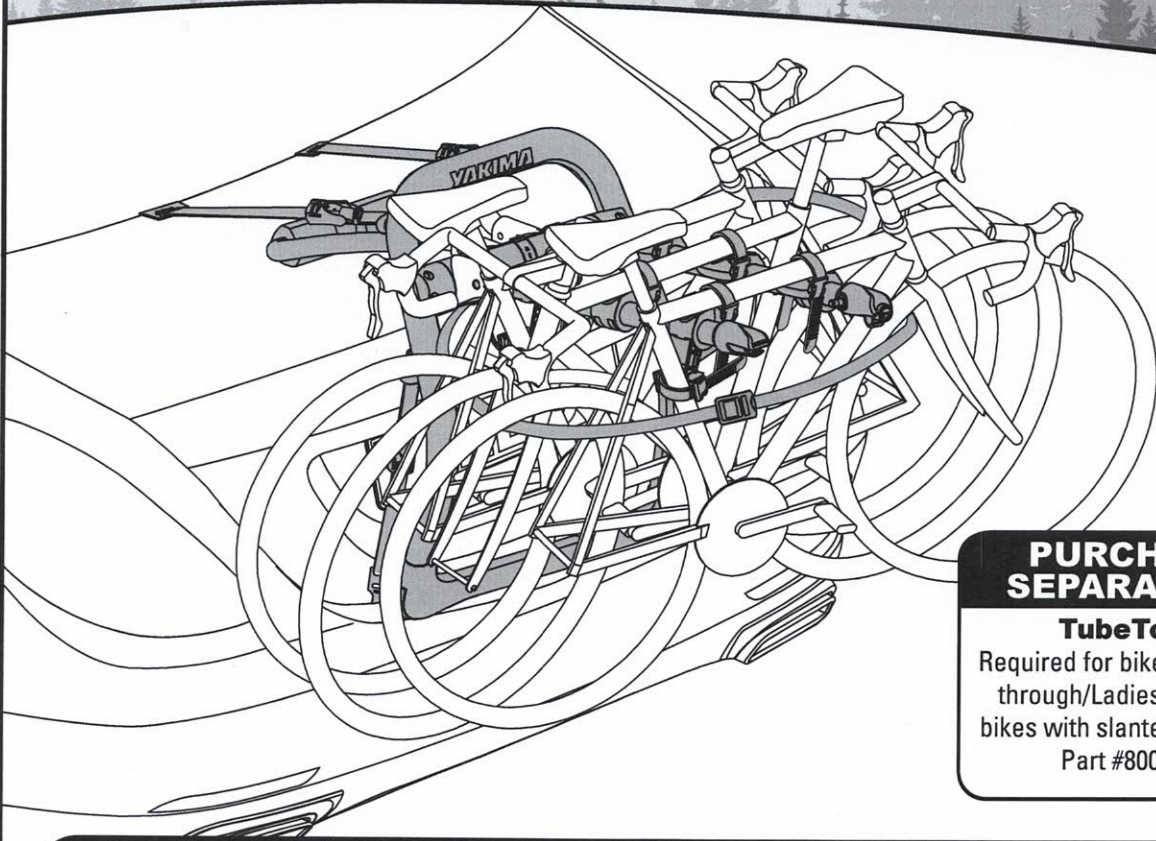

### PURCHASE SEPARATELY:

#### TubeTop™

Required for bikes with step-through/Ladies frames or bikes with slanted top tubes.  
Part #8002531

## CONTENTS • CONTENU • CONTENIDO

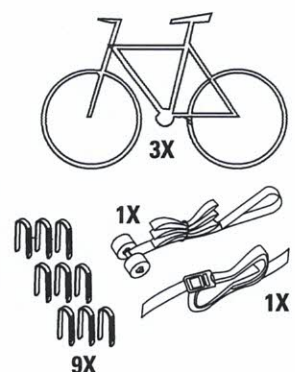
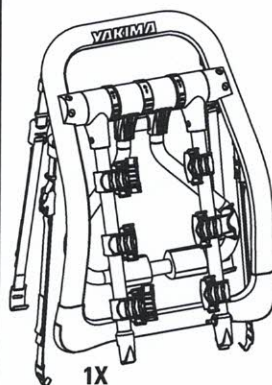
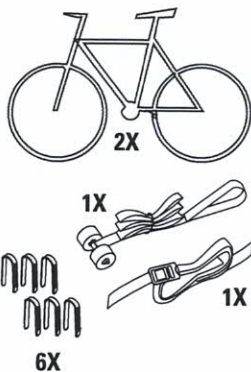
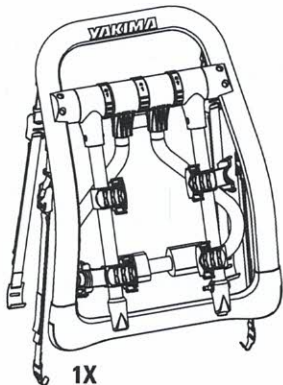

### FullBack (2 Bike)

35 lbs / 15.9 kg max per bike.  
70 lbs / 31.75 kg total.



### FullBack (3 Bike)

30 lbs / 13.6 kg max per bike.  
90 lbs / 40.8 kg total.

# INSTALLATION • MONTAGE • INSTALLATION

**1**



[www.fitlookup.yakima.com](http://www.fitlookup.yakima.com)

**HUB SETTING**



**FIT NOTES**



**2**

**Clean the vehicle**



**3**

**Set the hub**

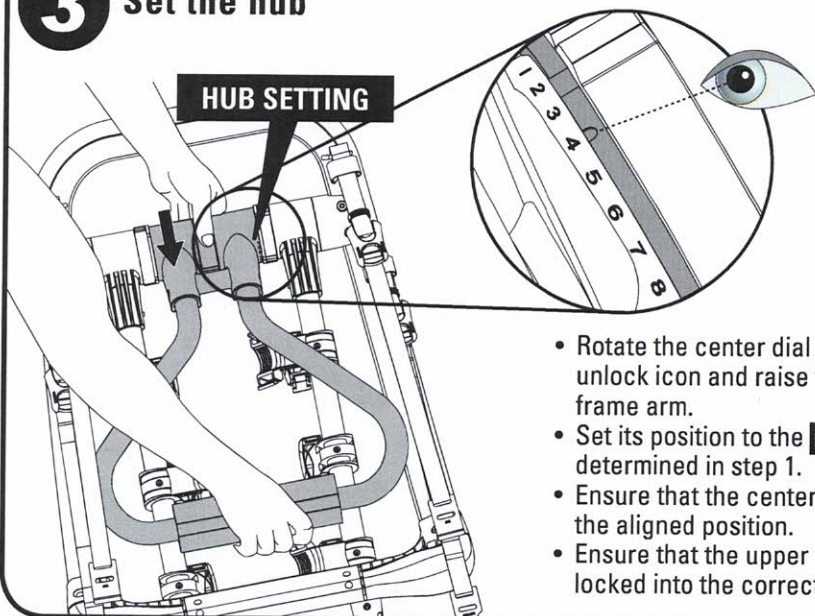

**HUB SETTING**

- Rotate the center dial toward the unlock icon and raise the upper frame arm.
- Set its position to the **HUB SETTING** you determined in step 1.
- Ensure that the center dial returns to the aligned position.
- Ensure that the upper frame arm is locked into the correct position.

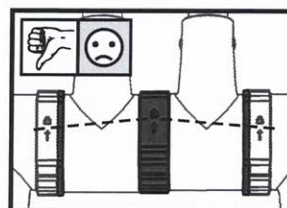
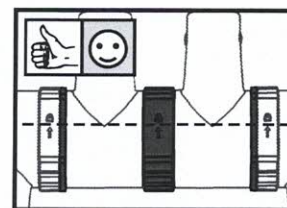

## OPTIONAL • FACULTATIF • OPCIONAL

**Install trunk security strap.**

**Wicking of moisture into the vehicle may occur in wet conditions.**

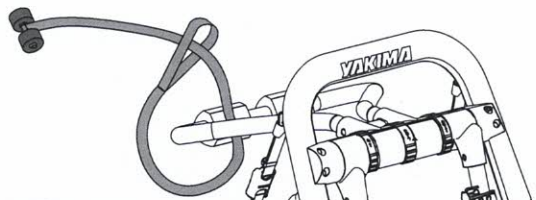

Thread strap end of trunk security strap around frame, and insert anchor end of trunk security strap through loop as shown.

Open trunk or hatch. Insert anchor end of trunk security strap through opening between trunk or hatch and the vehicle. Be sure strap is between the hinges of trunk or hatch. Close the trunk or hatch.

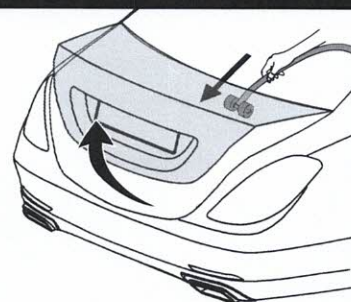

## 4 Position the FullBack



**TO AVOID DAMAGE, ALWAYS POSITION FULLBACK WHERE DETERMINED BY YOUR VEHICLE SPECIFIC **FIT NOTES**.**

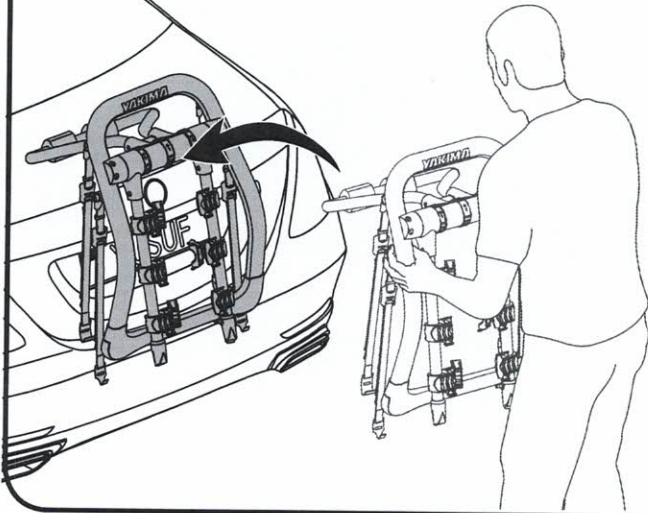

### Upper Frame:

- The position is relative to the lower frame and will depend on vehicle shape.
- Any contact with a spoiler is not acceptable

### Lower Frame:

- **LOWER SUPPORT FRAME LOCATION IS EXTREMELY IMPORTANT IN SUPPORTING THE LOAD!**
- A common location is just above the bumper on the bottom edge of the trunk or hatch.
- **Use area with the greatest support.**
- Do not place the lower frame on glass, plastic, or thin metal.
- Many vehicle trunks and liftgates have a large section of poorly supported metal that will dent under weight.
- **Do not place FullBack on vehicle's emblem.**



**DID YOUR **FIT NOTES** INDICATE YOU NEED TO USE ANCHORS FOR THE TOP HOOKS?**

**YES**

**SKIP STEP 5 AND PROCEED TO PAGE 4.**

**NO**

**PROCEED TO STEP 5.**

## 5 Attach top hooks

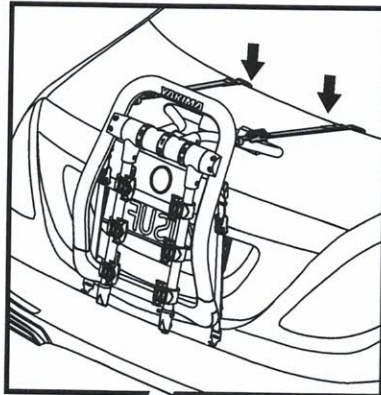
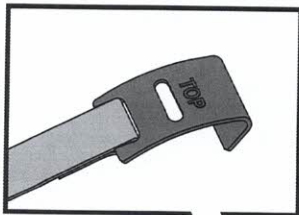

- Using your body to help support the FullBack attach both top strap hooks around the top edge of the trunk lid, hatch lid or rear door. Tighten top straps until FullBack is held in place.
- You may need to attach hooks at a wider section of the seam and then slide them into their recommended place on the vehicle.
- Straps should be parallel, and no wider than the body of the FullBack. Route the straps over the FullBack frame.
- **Not able attach the top hook? Use the anchor configuration.** Follow Anchor installation instructions on **PAGE 4**.
- **DO NOT ATTACH THE TOP HOOKS TO PLASTIC OR TO A SPOILER.** Use the Anchor configuration instead. Follow Anchor installation instructions on **PAGE 4**.
- **DO NOT ATTACH THE TOP HOOKS TO GLASS.** Use the Glass Hatch Hooks (sold separately - Yakima Part Number 8002612).
- **REMOVE HOOKS BEFORE OPENING THE HATCH OR TRUNK!** Opening the hatch or trunk with hooks installed could cause damage to the vehicle.

**PROCEED TO PAGE 5.**

# TOP HOOKS: Anchor installation instructions



Confirmed your vehicle does not require Anchors? Skip this page.

**A**

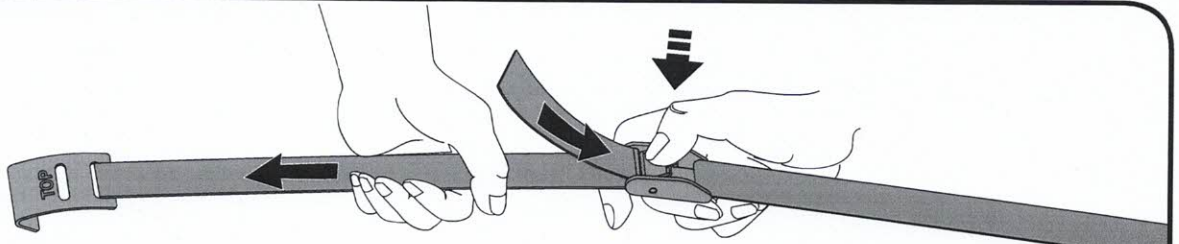

**B**

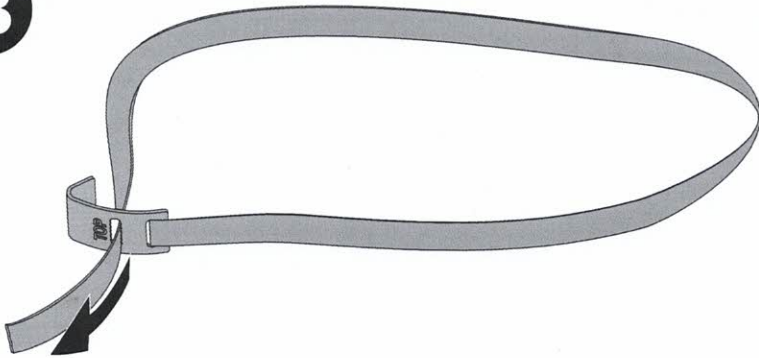

**C**

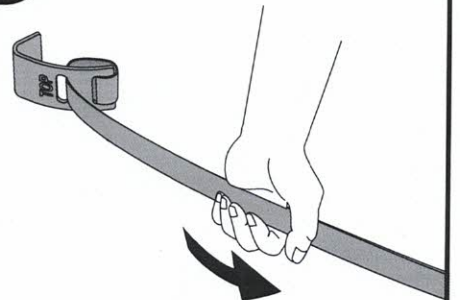

**D**

*Make sure the anchor is free from contact between hatch door and vehicle's frame*

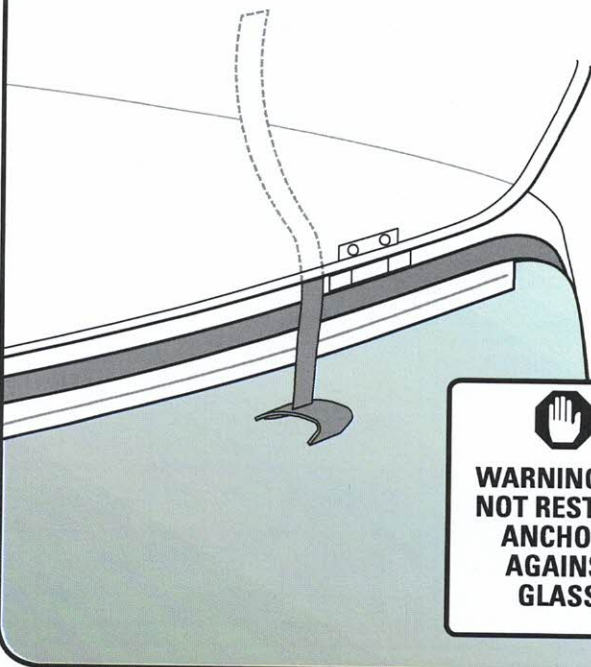

**WARNING: DO NOT REST THE ANCHORS AGAINST GLASS.**

**E**

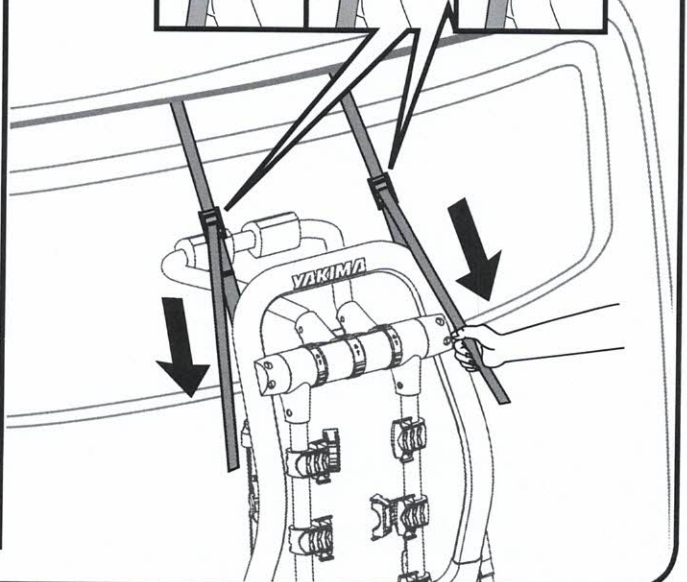
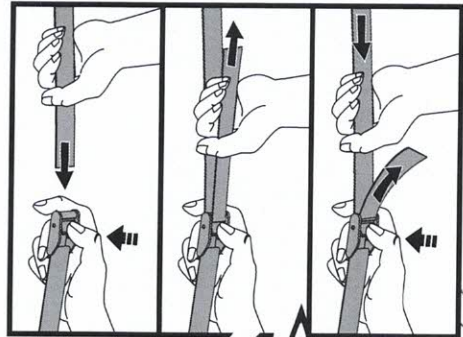



**DID YOUR FIT NOTES INDICATE YOU NEED TO USE ANCHORS FOR THE BOTTOM HOOKS?**

**YES**

**SKIP STEP 6 AND PROCEED TO PAGE 6.**

**NO**

**PROCEED TO STEP 6.**

## **6 Attach bottom hooks**

- Acceptable attachment points may include the bottom edge of the trunk, hatch lid or rear door. Additionally, the tie-down hooks underneath the vehicle or the metal ledge of the bumper are acceptable. Only attach hooks to areas with sufficient support.
- You may need to attach hooks at a wider section of the seam and then slide them into their recommended place on the vehicle.
- Not able to attach the bottom hooks? Use the Anchor configuration. Follow Anchor installation instructions on page 6.
- **DO NOT ATTACH THE BOTTOM HOOKS TO PLASTIC OR TO A SPOILER.** Use the Anchor configuration instead. Follow Anchor installation instructions on page 6.
- **DO NOT ATTACH THE BOTTOM HOOKS TO GLASS.** Use the Glass Hatch Hooks (sold separately - (Yakima Product Number 8002612).
- **REMOVE HOOKS BEFORE OPENING THE HATCH OR TRUNK!** Opening the hatch or trunk with hooks installed could cause damage to the vehicle.

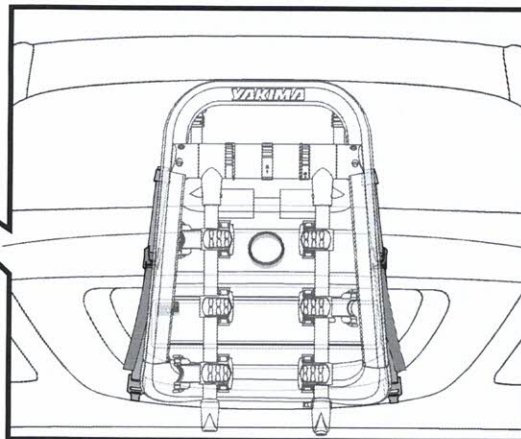
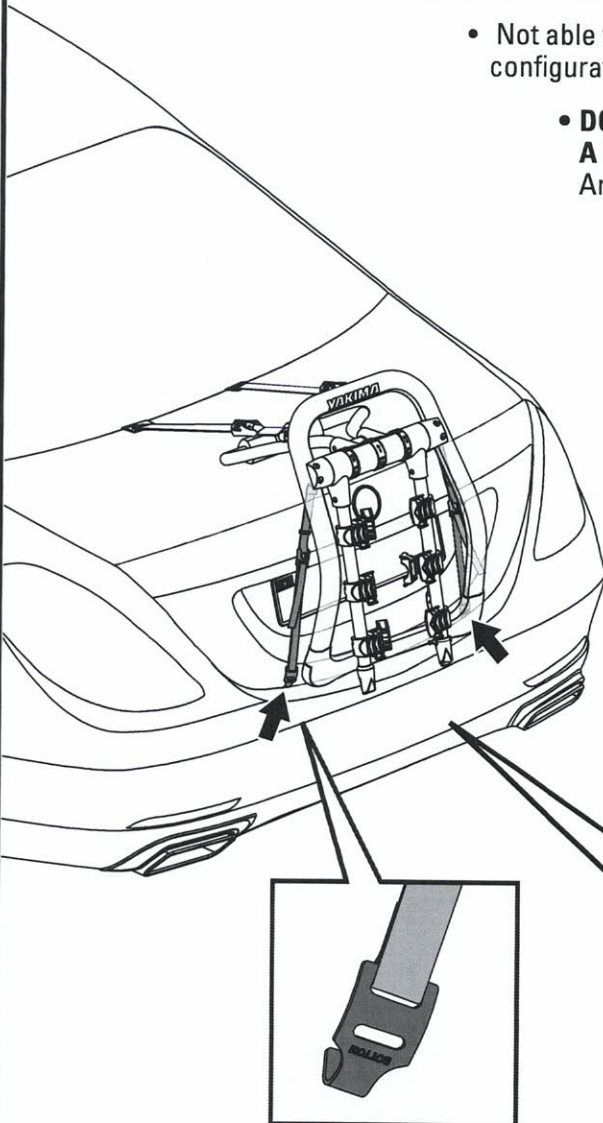

**PROCEED TO PAGE 7.**

## BOTTOM HOOKS: Anchor installation instructions



Confirmed your vehicle does not require Anchors? Skip this page.

**A** REMOVE THE CARRIER FROM THE CAR.

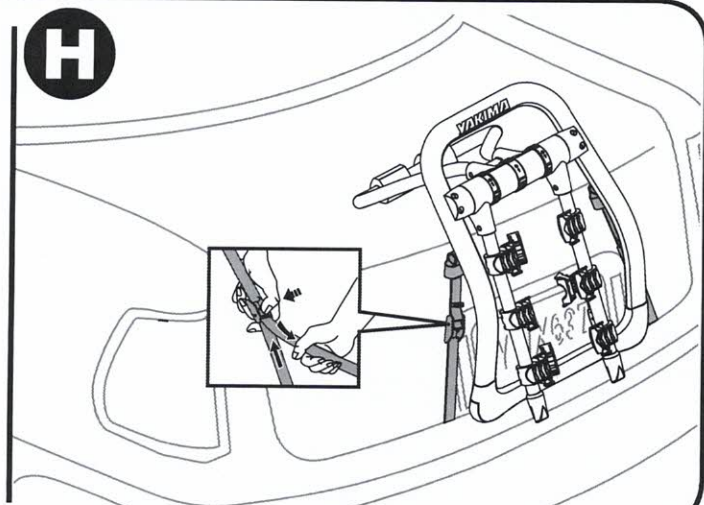
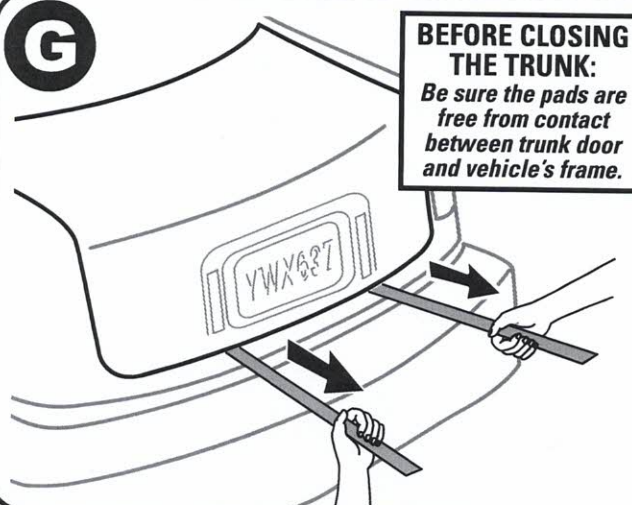
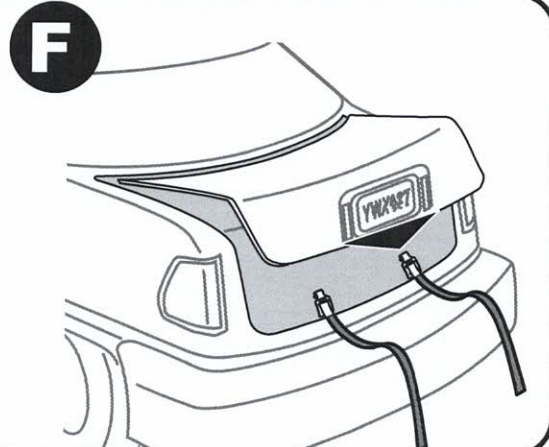
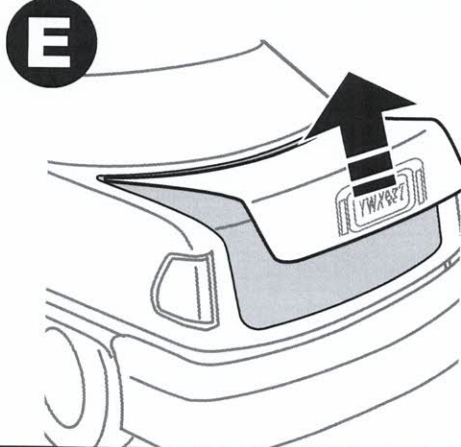
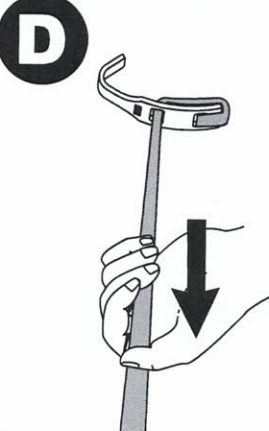
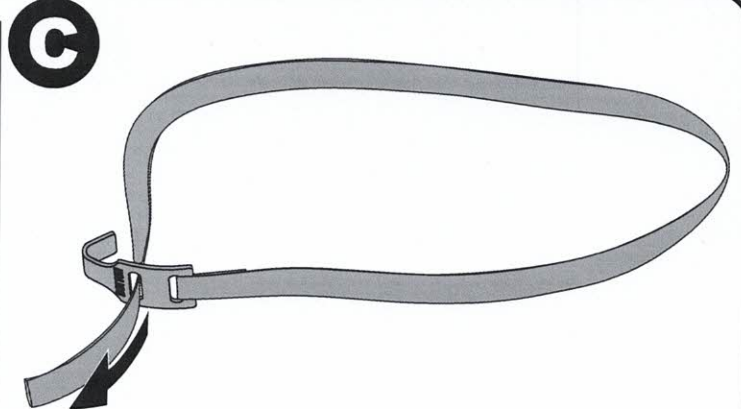
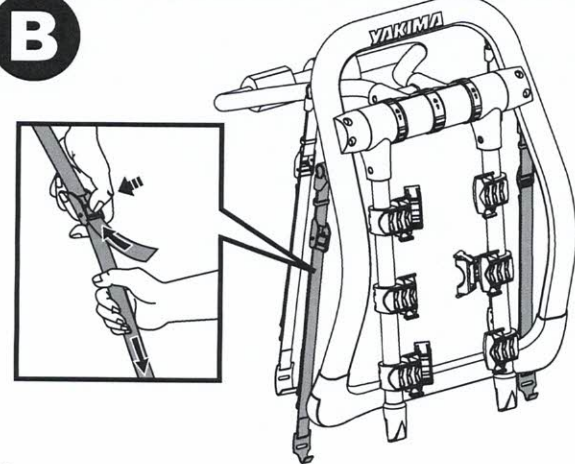

# 7

## Fully Tighten top straps

- Using ample force pull both top straps toward the front of the vehicle to fully tighten the top straps.

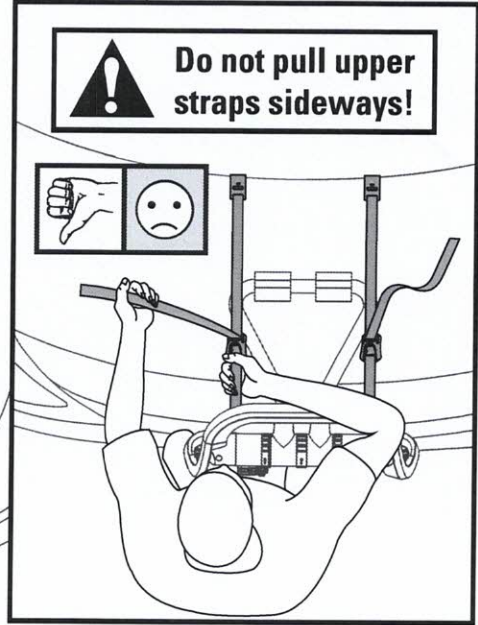
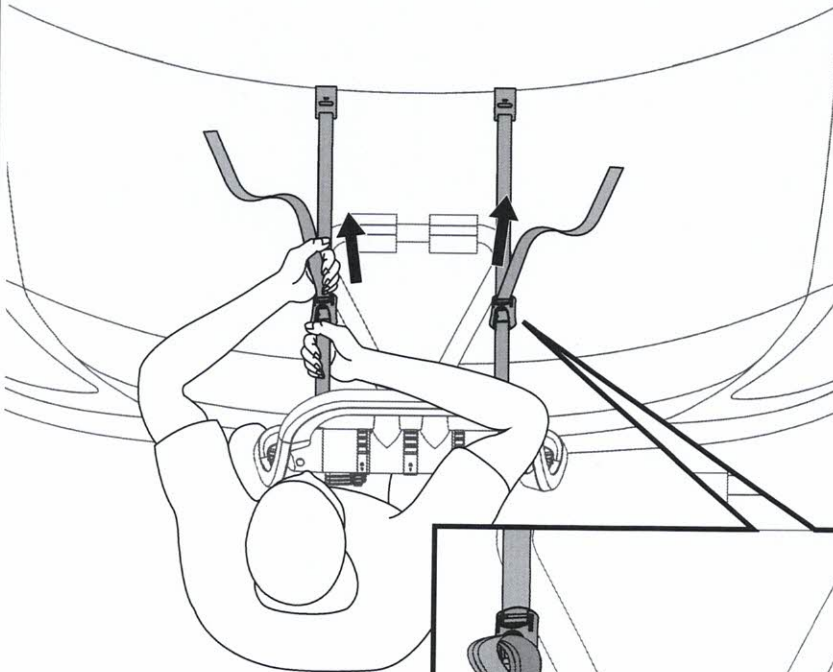

- Store the extra straps using the rubber strap storage bands.

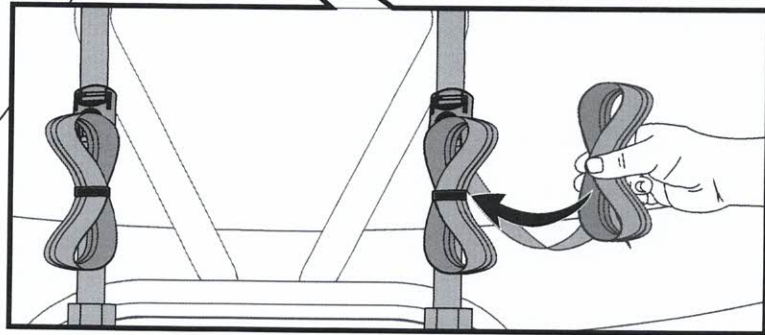

**2X**

# 8

## Fully Tighten bottom straps

- Using ample force pull both bottom straps down toward the ground to fully tighten the bottom straps.
- Store the extra straps using the rubber strap storage bands.

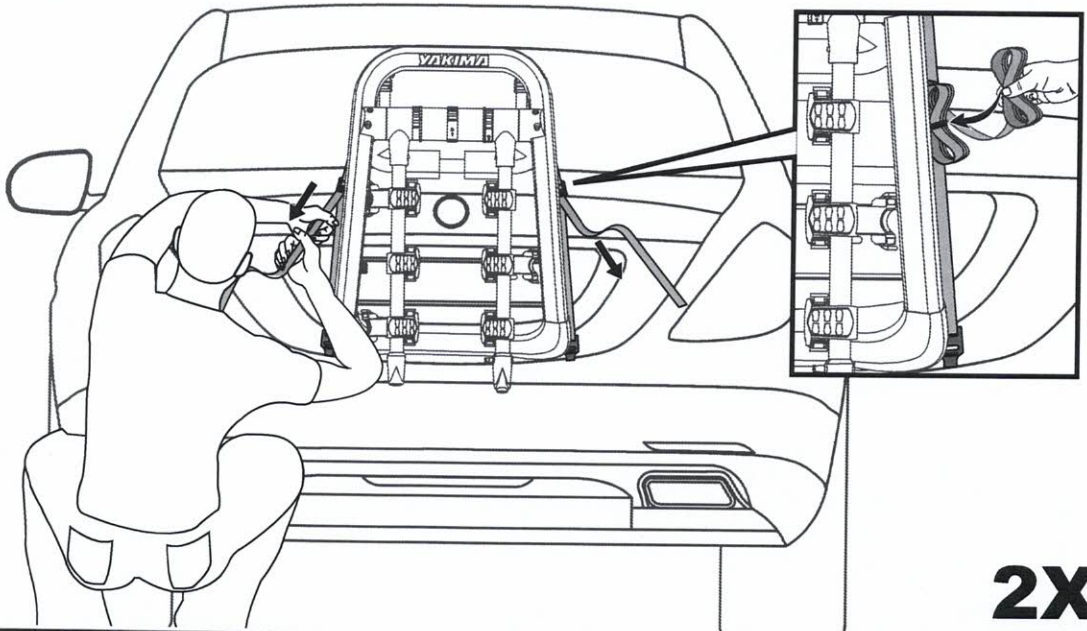

**2X**

## 9 Test installation

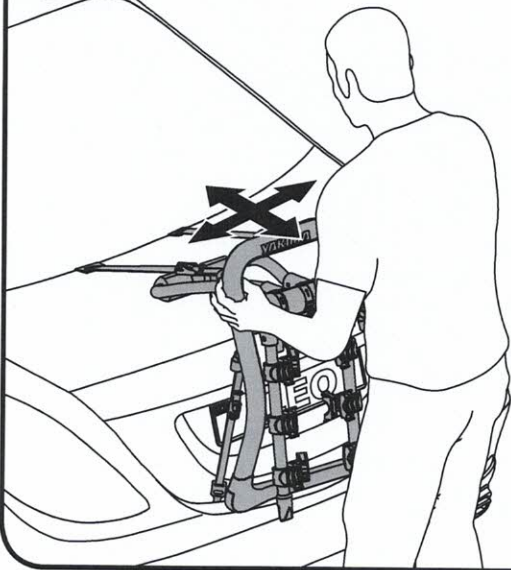

Grasp the FullBack and test that it's securely fastened to the vehicle by trying to move it in all directions. **FULLBACK SHOULD NOT MOVE!**



Any Contact with a spoiler is unacceptable.

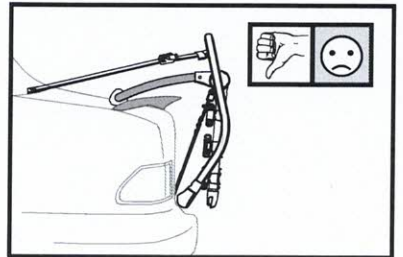
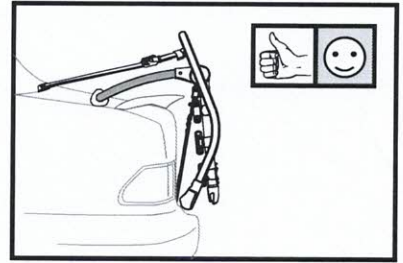

## LOADING • CHARGEMENT • CARGA

## 10 Raise the support arms

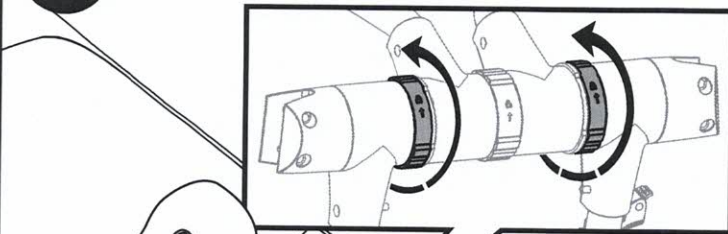

- Rotate the left and right dials toward the unlock icon and raise the support arms.
- Support arms must be parallel to one another, and angled slightly upward.
- Pull downward on both support arms to ensure they are locked into position. The lock icons will be aligned when locked.

Ensure that the left and right dials return to their locked positions.

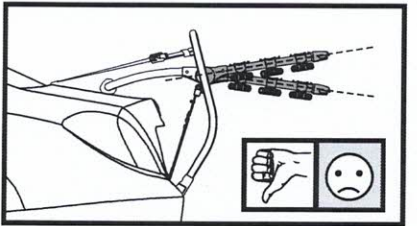
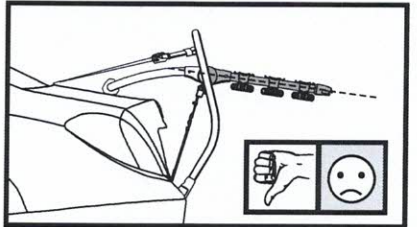
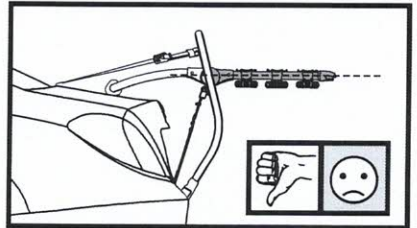
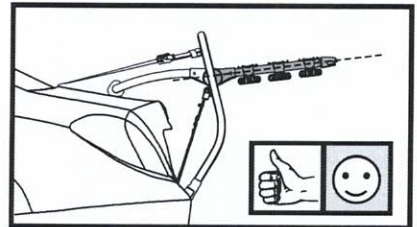
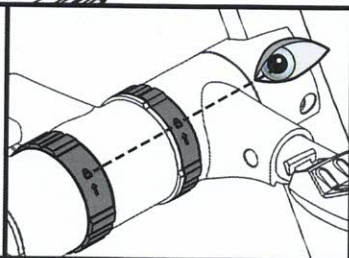



# 11 Load Bikes

- Bikes are to be loaded in the position closest to the vehicle

- Load heaviest bike first.

- Always load first bike with chain away from vehicle.

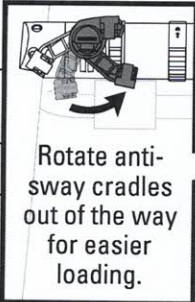

A Yakima TubeTop™ (see cover page) may be *required* to carry your bike safely.

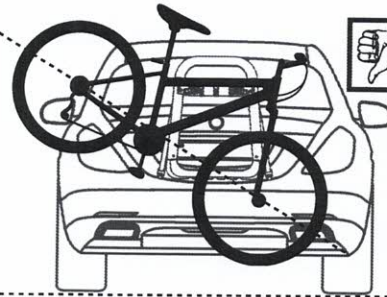
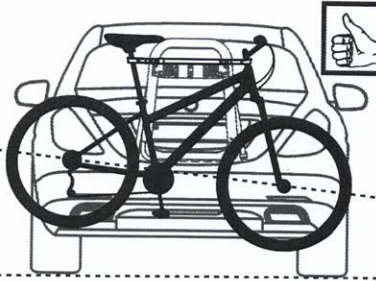

Failure to load bikes properly can result in property damage, personal injury, or death.

Bikes should be as level as possible to avoid ground clearance issues and possible ejections.

# 12 Secure the bikes

- Rotate anti-sway cradle against the seat tube.
- Insert ZipStrips™ into cradles and push against bike frame until snug.

- Each bike requires three ZipStrips™.

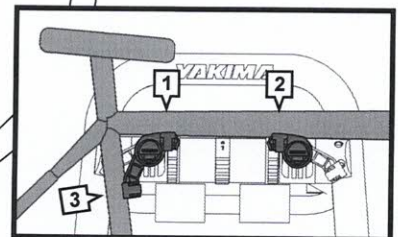
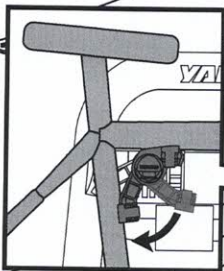

### 13 Install safety strap.

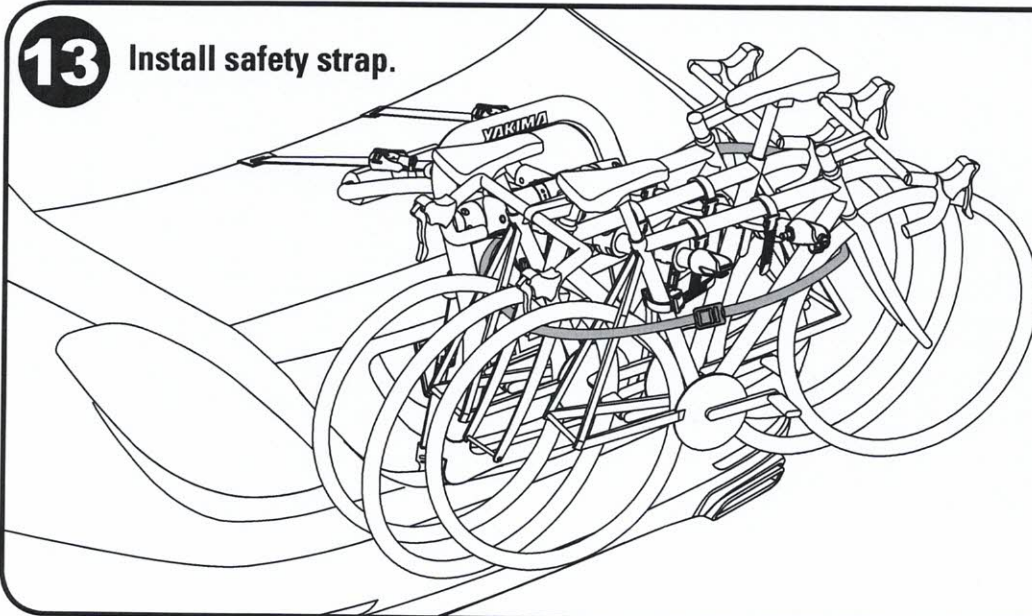

Use the included safety strap to secure your bikes to the carrier. Route the strap through each wheel, around the carrier. Feed the strap through the buckle, tighten it down, and secure the loose end.

### 14 Lock bikes

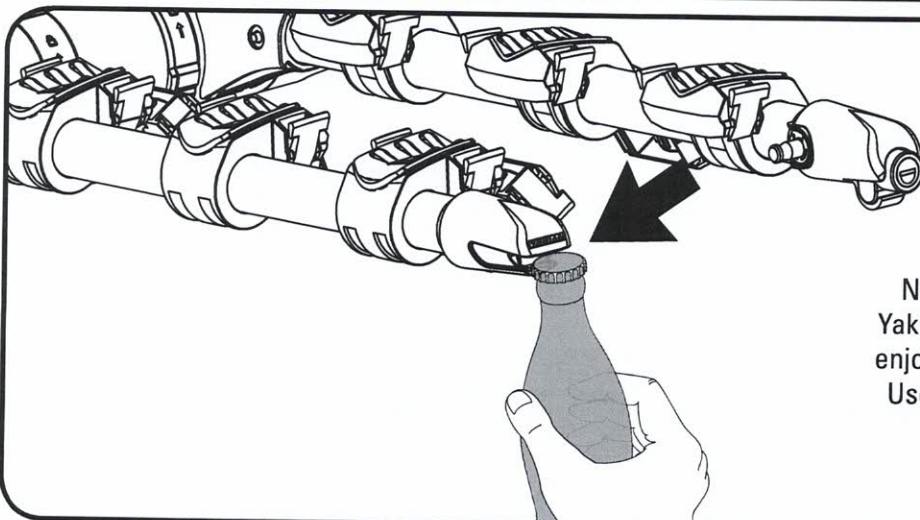
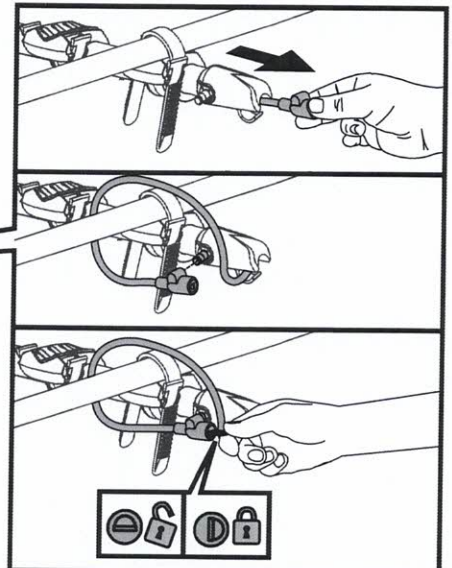
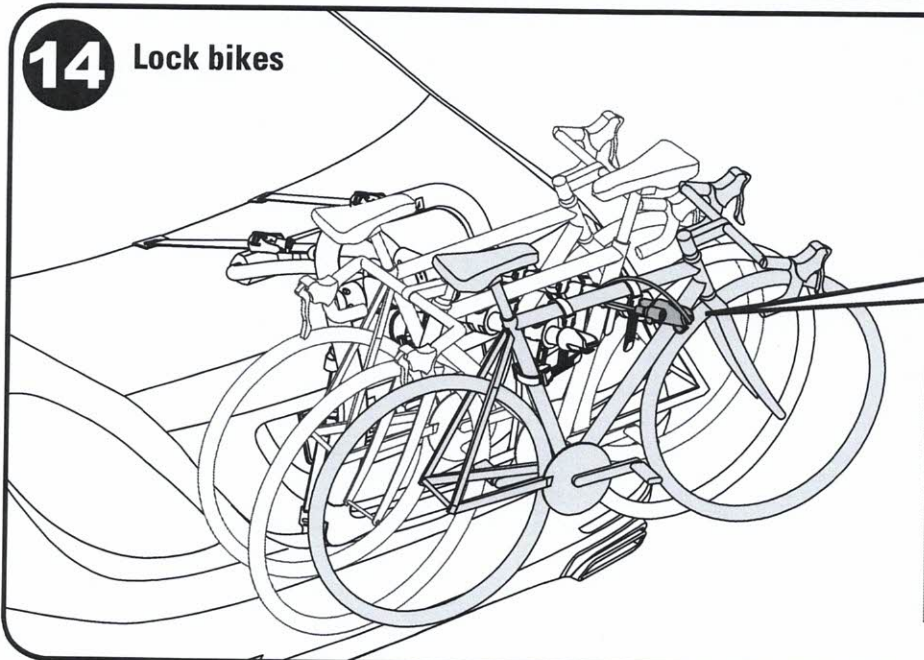

Now that you've installed your Yakima FullBack take a moment to enjoy the beverage of your choice. Use the built in bottle openers to crack open a cold one!

UNLOADING • DÉCHARGEMENT • DESCARGA

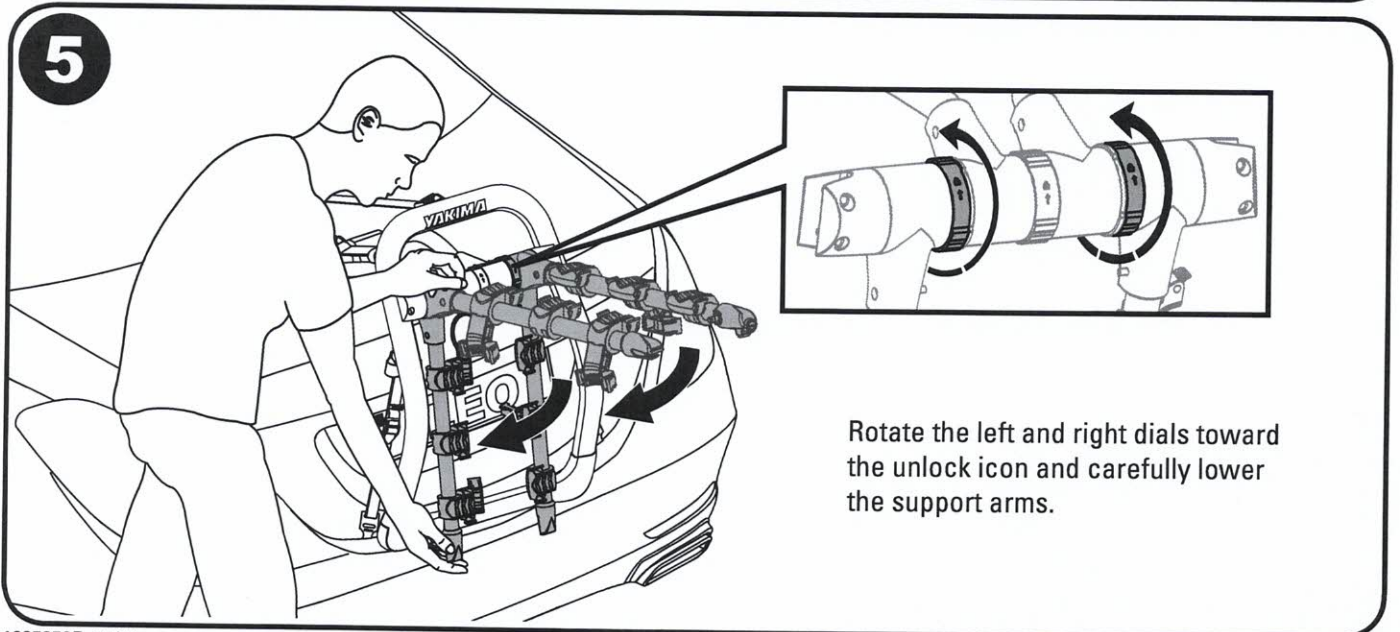
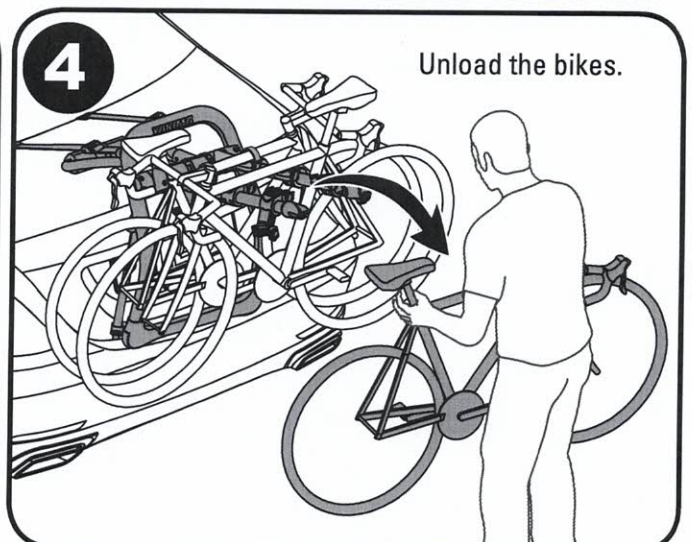
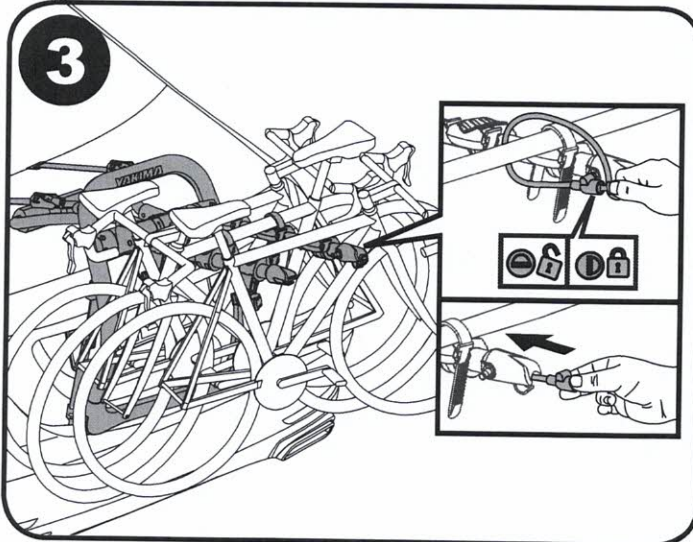
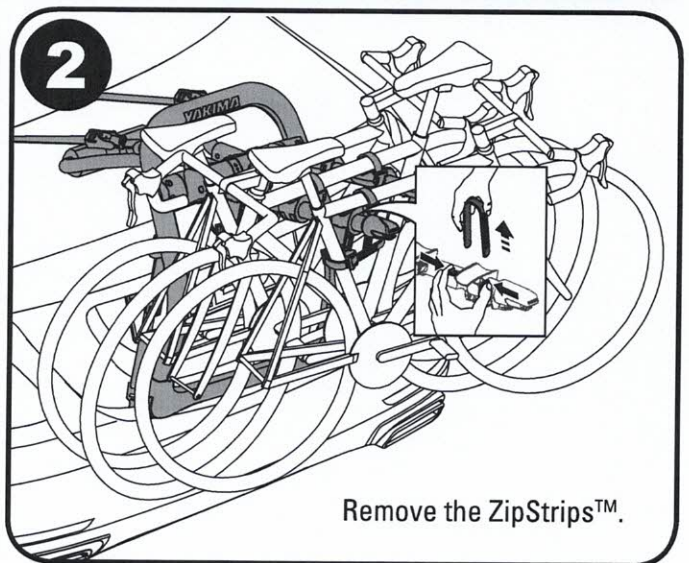
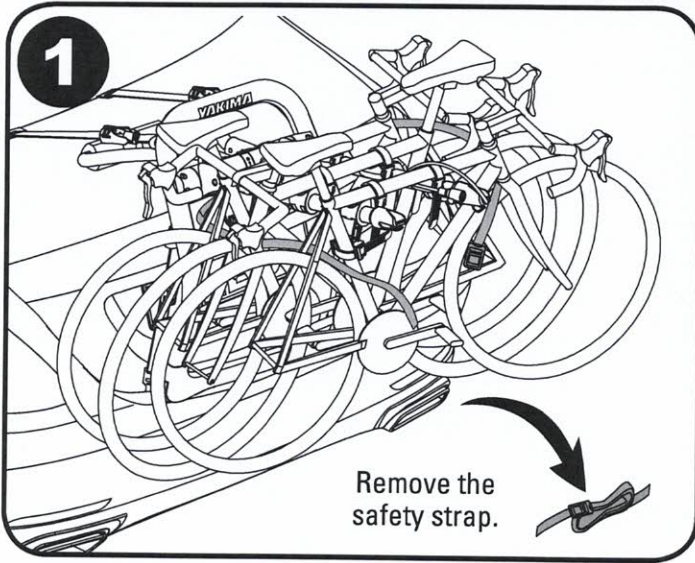

# REMOVAL • DÉPOSE • DESMONTAJE

1

Press the button on the buckle and release some tension from the straps

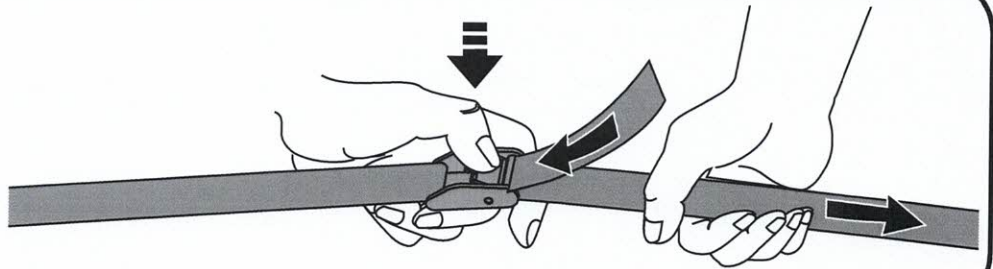

2

- Unhook the bottom hooks.
- While using your body to support the FullBack remove the top hooks.

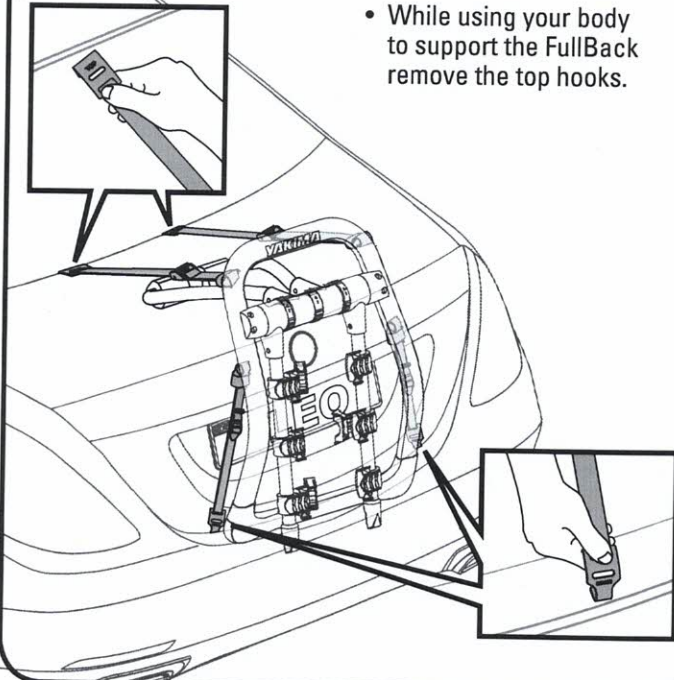

3

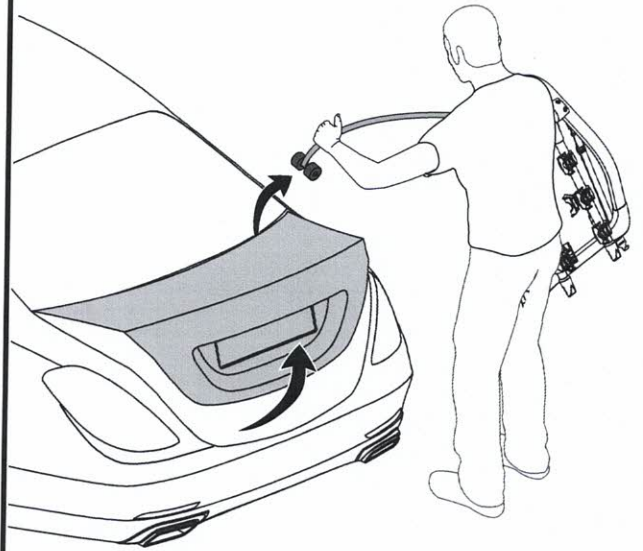

4

Carefully remove the FullBack from the vehicle.

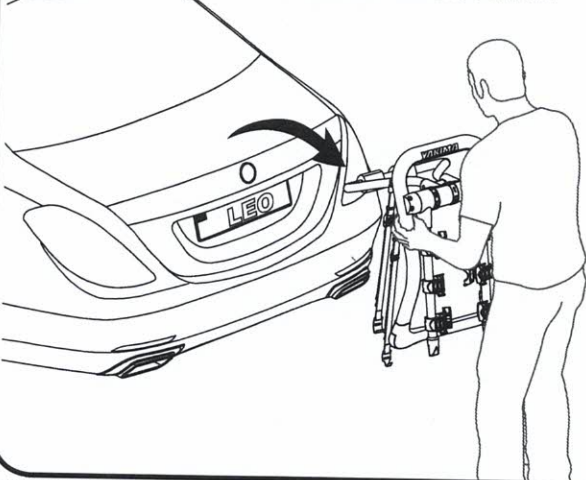

5

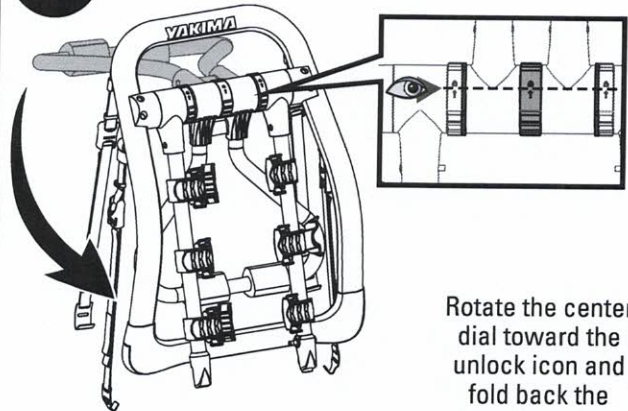

Rotate the center dial toward the unlock icon and fold back the upper frame arm.

## STRAP TENSION



Check strap tension before each use, and while in use check strap tension often, tighten with each new load.

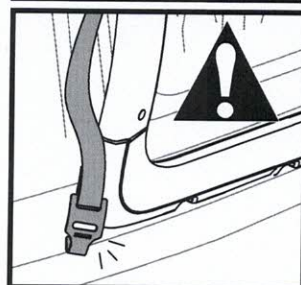
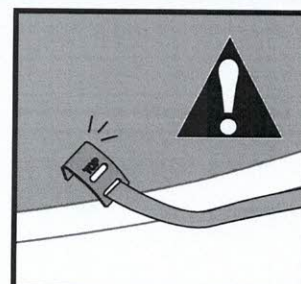
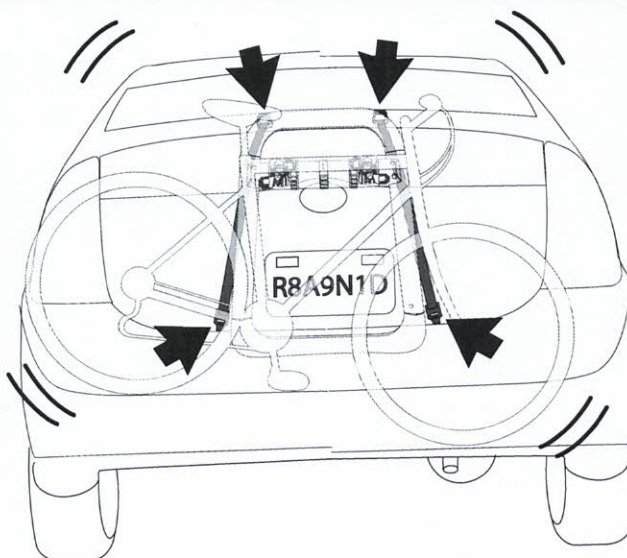

## IMPORTANT!

Be sure to read all the warnings and warranty information contained in the insert accompanying these instructions!

## FULLBACK WEIGHT

2 Bike Rack = 21 lbs (9.5kg)

3 Bike Rack = 23 lbs (10.5kg)

## WEIGHT LIMITS

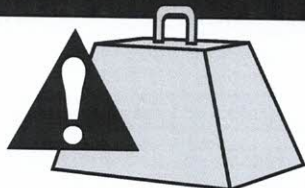

### FullBack (2 Bike)

35 lbs / 15.9 kg max per bike.  
70 lbs / 31.75 kg total.

### FullBack (3 Bike)

30 lbs / 13.6 kg max per bike.  
90 lbs / 40.8 kg total.

## CAUTION! BEFORE EACH USE:

- MAKE SURE ALL THREE ADJUSTMENT DIALS ARE IN THE LOCKED POSITION.
- CHECK STRAP TENSION BEFORE EACH USE, AND WHILE IN USE CHECK STRAP TENSION OFTEN, TIGHTEN WITH EACH NEW LOAD.
- KEEP BICYCLE TIRES AND STRAPS AWAY FROM VEHICLE'S EXHAUST.
- NEVER DRIVE OFF-ROAD WITH BICYCLES LOADED.
- YOU MUST TIGHTEN STRAPS AFTER LOADING BIKES.
- FAILURE TO CHECK AND TIGHTEN STRAPS CAN RESULT IN PROPERTY DAMAGE, PERSONAL INJURY, OR DEATH.
- DO NOT LET BIKE PEDALS TOUCH THE VEHICLE.
- REMOVE ANY BIKE ATTACHMENTS PRIOR TO TRANSPORT.

## IMPORTANT GUIDELINES:

- CERTAIN AUTOMOTIVE AFTERMARKET PRODUCTS SUCH AS SPOILERS, ANTENNAE, ETC. MAY PREVENT ATTACHMENT OF THE CARRIER.
- EXCESSIVE TIGHTENING OF THE STRAP MAY CAUSE DAMAGE TO SOFTER BODY MATERIALS.
- NOT APPROVED FOR TANDEM OR RECUMBENTS.
- DO NOT INSTALL ONTO TRAILERS, CAMPERS, OR RVs.
- NEVER OPEN TRUNK/HATCH WITH CARRIER INSTALLED. OPENING THE HATCH OR TRUNK WITH CARRIER INSTALLED COULD CAUSE DAMAGE TO THE VEHICLE.
- REPLACE ANY OF THE STRAPS THAT APPEAR WORN OR FRAYED (CONTACT YOUR DEALER).
- HALFBACK/FULLBACK MAY NOT WORK ON VEHICLES WITH AUTOMATIC OR POWER LIFT GATES.

## MAINTENANCE:

Use a soft cloth with water and mild detergent to clean plastic parts.

## CAUTION

REMOVE HALFBACK/FULLBACK BEFORE ENTERING AN AUTOMATIC CAR WASH.

## READ THE INSTALLATION CAUTIONS THAT APPLY TO YOUR VEHICLE

### Rear Window Wiper

- Wiper may not be usable while carrier is installed. Do not allow wiper to contact any part of this carrier, at any time.

### Vehicles with a Spoiler

- If any part of the carrier contacts the spoiler, do not use this product.

### Spoiler Gap

- SUV's, vans, and wagons with a gap between the rear spoiler and rear window or hatch must route upper straps under the spoiler when possible. Do not allow straps to contact spoiler.

### Glass Hatches

- If upper or lower hooks must attach to glass, follow instructions to use Glass Hatch Hooks (sold separately).

### Convertibles

- Do not allow the upper frame of the carrier to rest on car convertible top.
- Do not raise or lower top while carrier is installed.

### Tight Seams

- On some vehicles the trunk/hatch seams may be too tight to easily insert hooks. Slide hooks from outside edge of trunk/hatch to appropriate location. If still too tight, open trunk/hatch, insert hooks, and close very carefully to avoid damage.
- Make sure trunk/hatch is securely closed before continuing installation.

### Soft Attachment Points

- Excessive tightening of the straps may cause damage to softer body materials.

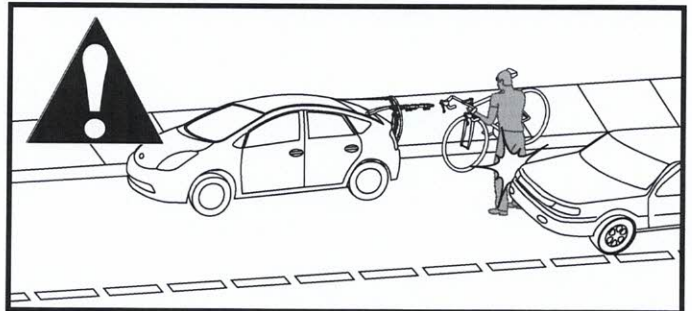
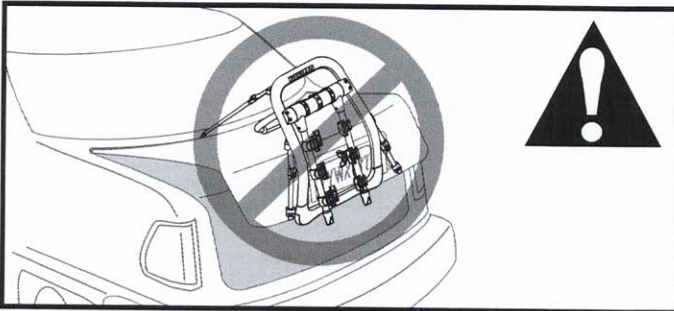

## RECOMMENDED ACCESSORIES (SOLD SEPARATELY)



**YAKIMA 9FT SECURITY CABLE**  
(YAKIMA PART NUMBER 8007233)  
Secures your bikes to your carrier.

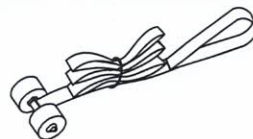

**TRUNK SECURITY STRAP**  
(YAKIMA PART NUMBER 8002623)  
Secures your carrier to your vehicle.



**YAKIMA TUBETOP™**  
(YAKIMA PART NUMBER 8002531)  
Recommended for bikes with slanted, or no bicycle top tubes.

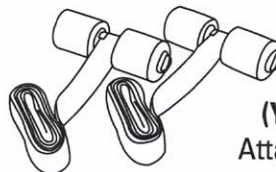

**GLASS HATCH HOOKS™**  
(YAKIMA PART NUMBER 8002612)  
Attaching Glass Hatch Hooks to upper strap will limit load to 2 bikes.

Go to [www.yakima.com](http://www.yakima.com) or contact your dealer to purchase.

**YAKIMA**  
[www.yakima.com](http://www.yakima.com)

**YAKIMA PRODUCTS, INC.**  
4101 KRUSE WAY  
LAKE OSWEGO, OR 97035-2541  
USA

**KEEP THESE INSTRUCTIONS!**