

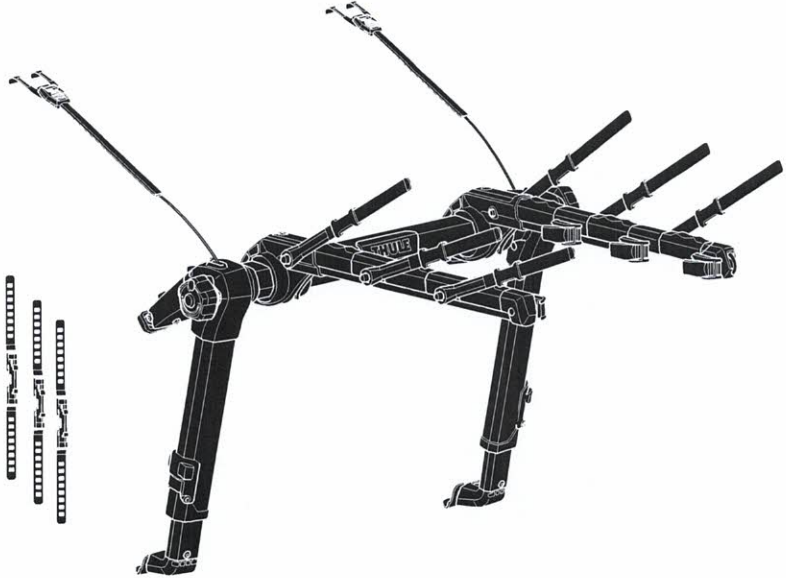

# > Instructions

## Thule OutWay Hanging 2&3

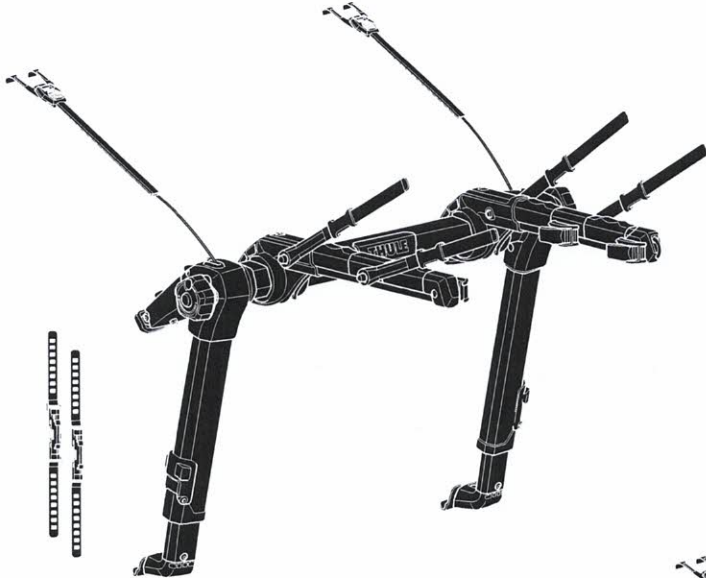

Bring your life  
thule.com

**EN** Rear door-mounted bike carrier  
**FR** Porte-vélos sur le hayon arrière  
**ES** Portabicicletas de portón trasero  
**DE** Heckklappen-Fahrradträger  
**NL** Fietsdrager voor op de achterklep  
**PT** Suporte para bicicleta para tampa traseira  
**IT** Portabici da installare sul portellone posteriore  
**SV** Bakluckemonterad cykelhållare  
**DK** Cykelholder, der er monteret på bagklap  
**NO** Bakdørmonteerte lasteholdere  
**FI** Tavaratilan oveen kiinnitettävä polkupyöräteline  
**IS** Hjólagrind á afturhurð  
**ET** Tagaluugile paigaldatav jalgrattahoidik  
**LV** Uz aizmugurējām durvīm uzstādāms velosipēdu turētājs  
**LT** Prie galinių durelių tvirtinami dviračių laikikliai  
**RU** Устанавливаемое на задней дверце крепление для велосипедов  
**UK** Багажник для велосипедів, що монтується на задніх дверцятах  
**PL** Bagażnik rowerowy montowany na tylnych drzwiach  
**CS** Nosič jízdních kol s montáží na zadní dveře  
**HU** Hátsó ajtóra szerelhető kerékpártartó  
**RO** Suport pentru bicicletă montat pe ușa din spate  
**SK** Nosič bicyklov s montážou na zadné dvere

**SL** Prtljažnik za kolesa za na zadnja vrata vozila  
**BG** Багажник за велосипеди, монтиран на задната врата  
**HR** Nosač bicikla koji se postavlja na vrata prtljažnika  
**EL** Σχάρα ποδηλάτου πίσω πόρτας  
**TR** Araç arkasına bağlanan bisiklet taşıyıcı  
**MT** Pengangkut basikal yang dipasang pada pintu belakang

**HE** מנשא אופניים המורכב על הדלת האחורית

**AR** حامل الدراجة للتثبيت على الباب الخلفي

**ZH (CN)** 后备箱安装托架

**ZH (TW)** 後車門自行車架

**JA** リアドアマウント型サイクルキャリア

**KO** 뒷문 장착 자전거 캐리어

**TH** โครงยึดจักรยานแบบติดตั้งกับประตูท้ายรถ

**MS** Gari tar-roti mmuntat fuq il-bieba ta' wara

**CITY CRASH**

Compatible with ISO norms

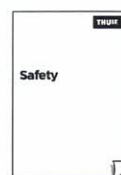

**Thule OutWay Hanging 2**  
994001, 994005



**Thule OutWay Hanging 3**  
995001, 995005

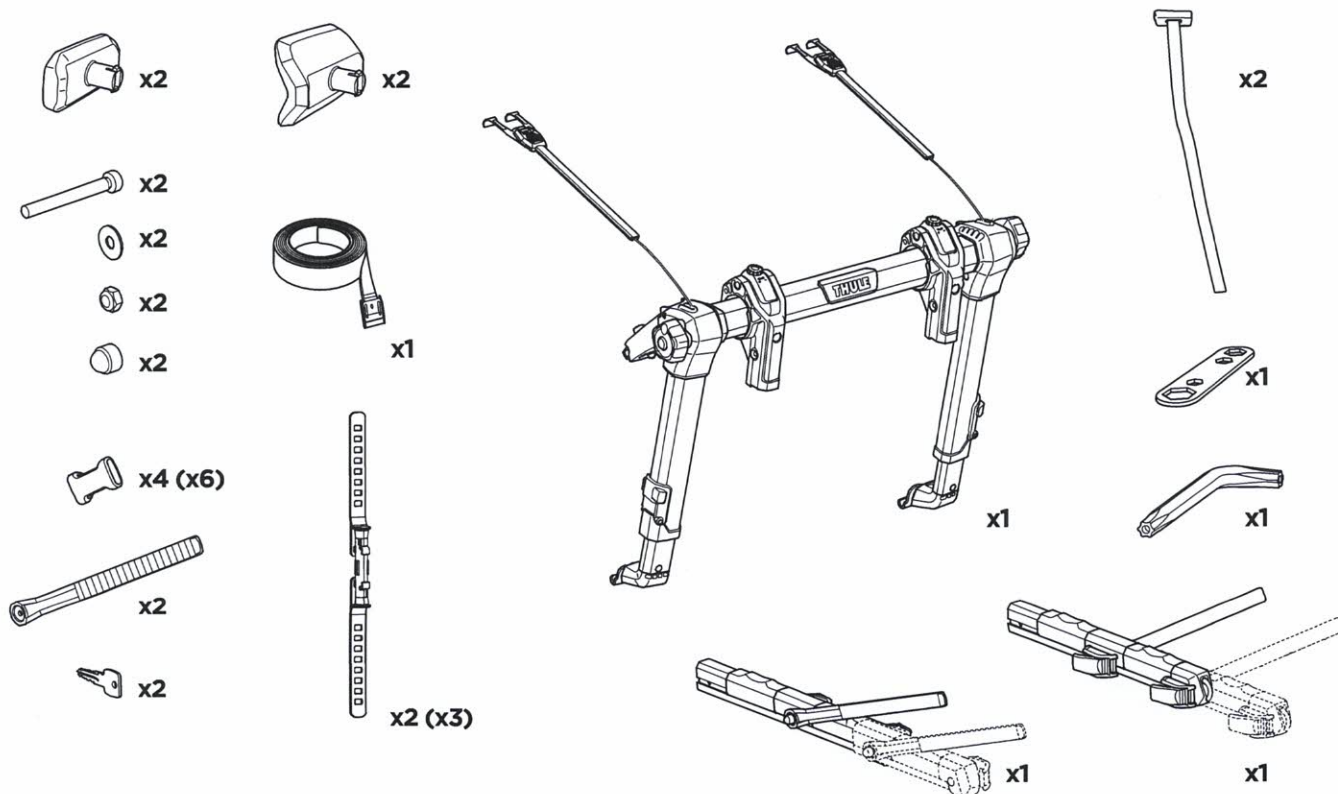

**>Mounting Tutorial**  
Thule OutWay Hanging 2&3

**THULE**  
SWEDEN



[www.thule.com](http://www.thule.com)  
[www.youtube.com](http://www.youtube.com)

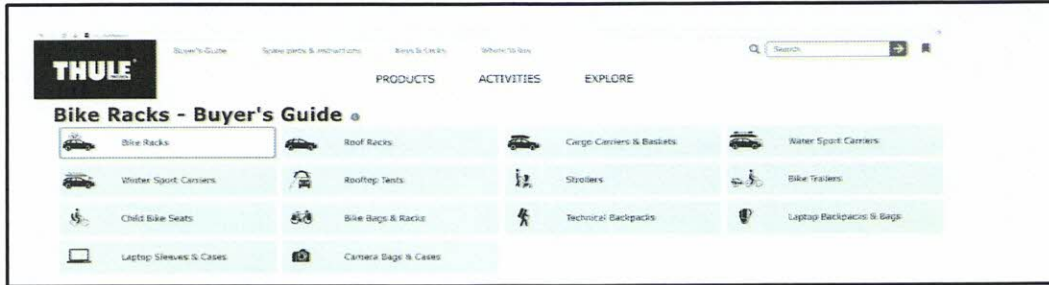
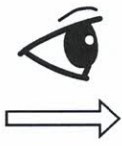

See Thule Mounting Tutorial video of Thule OutWay before installation!

1

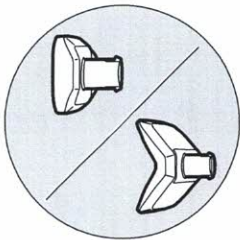

2

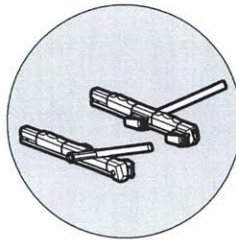

3

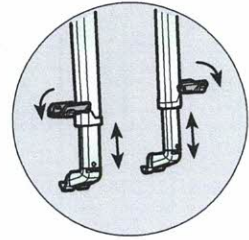

4

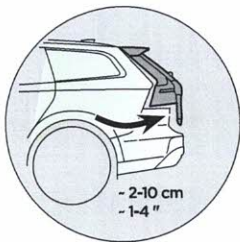

5

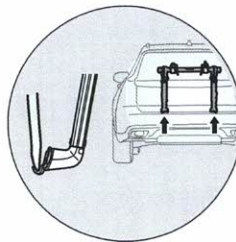

6

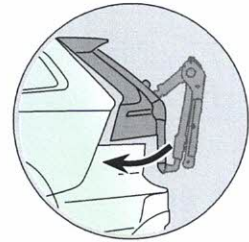

7



8

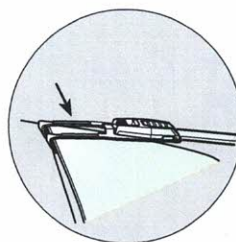

9

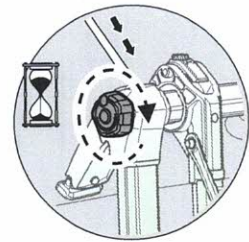

10



11

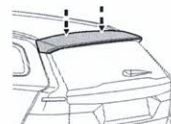

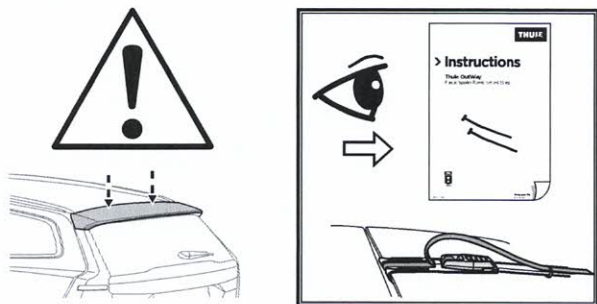

**EN** If plastic spoiler is in the area where upper hooks will be mounted, always use the spoiler kit with the reinforcement strap, according to separate instruction for **Plastic Spoiler Reinforcement Strap**.

**FR** Si le déflecteur en plastique se trouve dans la zone où les crochets supérieurs seront montés, utilisez toujours le kit pour déflecteur avec la sangle de renfort, conformément aux instructions séparées de la **Plastic Spoiler Reinforcement Strap**.

**ES** Si hay un alerón de plástico en el área en la que se van a montar los ganchos superiores, use siempre el kit para alerón con la correa de refuerzo, de acuerdo con las instrucciones independientes de la **Plastic Spoiler Reinforcement Strap**.

**DE** Wenn sich der Kunststoff-Spoiler in dem Bereich befindet, in dem die oberen Haken befestigt werden, verwenden Sie stets das Spoiler-Kit mit dem Verstärkungsriemen gemäß der separaten Anleitung für **Plastic Spoiler Reinforcement Strap**.

**NL** Bij het monteren van de bovenste haken op een kunststof spoiler, steeds gebruik maken van de spoilerkit met verstevigingsband. Volg daarbij de aparte instructies voor de **Plastic Spoiler Reinforcement Strap**.

**PT** Se houver um spoiler plástico na área em que os ganchos superiores serão montados, use sempre o kit de spoiler com a tira de reforço de acordo com as instruções separadas para a **Plastic Spoiler Reinforcement Strap**.

**IT** Se lo spoiler in plastica si trova nell'area dove saranno montati i ganci superiori, usare sempre il kit spoiler con la cinghia di rinforzo come indicato nelle istruzioni a parte per la **Plastic Spoiler Reinforcement Strap**.

**SV** Om en plastspoiler sitter i det område där de övre hakarna ska monteras, se då alltid till att använda ett spoiler-kit med förstärkande spännband, enligt separata instruktioner för **Plastic Spoiler Reinforcement Strap**.

**DK** Hvis der er en plastikspoiler omkring området, hvor krogene skal monteres, skal du altid bruge spoilersættet med den forstærkede rem, ifølge den særlige vejledning til **Plastic Spoiler Reinforcement Strap**.

**NO** Hvis plastspoileren er i området der de øvre krokene skal monteres, bruk alltid spoilersettet med forsterkningsstroppen i henhold til egen instruksjon for **Plastic Spoiler Reinforcement Strap**.

**FI** Jos yläkoukut asennetaan muovisen spoilerin läheisyyteen, käytä aina kiinnityshihnan sisältyvää spoilerisarjaa noudattamalla **Plastic Spoiler Reinforcement Strap** tarkoitettuja erillisiä ohjeita.

**IS** Ef lyftispillir úr plasti er á svæðinu þar sem efri krókarnir verða settir upp skal ávallt nota lyftispillissettið með styrkingarólinni, í samræmi við sérstakar leiðbeiningar fyrir **Plastic Spoiler Reinforcement Strap**.

**ET** Kui plastspoiler on piirkonnas, kuhu kinnitatakse ülemised konksud, tuleb spoilerikomplekti alati kasutada kinnitusrihmaga, järgides **Plastic Spoiler Reinforcement Strap** eraldi kasutusjuhendit.

**LV** Ja plastmasas spoileris atrodas vietā, kur tiks montēti augšējie āķi, noteikti lietojiet spoileru komplektu ar stiprinājuma siksnu atbilstoši atsevišķiem norādījumiem **Plastic Spoiler Reinforcement Strap**.

**LT** Jei plastikinis aptakas yra vietoje, kurioje bus tvirtinami viršutiniai kabliai, aptako rinkinį visada naudokite su tvirtinimo dirželiu, vadovaudamiesi atskiromis **Plastic Spoiler Reinforcement Strap** instrukcijomis.

**RU** Если пластиковый спойлер находится в области монтажа верхних крюков, всегда используйте комплект спойлера с усиливающим ремнем в соответствии с отдельной инструкцией для **Plastic Spoiler Reinforcement Strap**.

**UK** Якщо пластиковий спойлер знаходиться в області, де буде прикріплено верхні гачки, завжди використовуйте набір спойлера зі зміцнювальним ремінцем, відповідно до окремої інструкції для **Plastic Spoiler Reinforcement Strap**.

**PL** Jeśli w miejscu gdzie będą montowane górne haki znajduje się spojler z tworzywa sztucznego, należy zawsze używać zestawu spojlera z taśmą wzmacniającą, zgodnie z oddzielną instrukcją do **Plastic Spoiler Reinforcement Strap**.

**CS** Pokud je plastový spojler v místě, kam se budou montovat horní háčky, vždy používejte spojlerovou sadu s vyztužovacím popruhem podle samostatných pokynů pro **Plastic Spoiler Reinforcement Strap**.

**HU** Ha a műanyag légterelő azon a helyen van, ahová a felső horgokat fel kell szerelni, mindig használja a légterelő-készletet a megerősítő hevederrel, a **Plastic Spoiler Reinforcement Strap** külön utasításai szerint.

**RO** Dacă spoilerul din plastic se află în zona în care vor fi montate cârligele superioare, utilizați întotdeauna kitul spoilerului cu chinga de fixare, în conformitate cu instrucțiunile separate pentru **Plastic Spoiler Reinforcement Strap**.

**SK** Ak sa na mieste, kde budú namontované horné háčky, nachádza plastový spojler, vždy použite súpravu pre spojler s výstužným popruhom podľa samostatného pokynu pre **Plastic Spoiler Reinforcement Strap**.

**SL** Če je plastični usmernik zraka na območju, kjer bodo nameščeni zgornji kavljji, vedno uporabite komplet usmernika zraka z ojačevalnim trakom v skladu z ločenimi navodili za **Plastic Spoiler Reinforcement Strap**.

**BG** Ако пластмасовият спойлер е в зоната, където ще бъдат монтирани горни куки, винаги използвайте комплекта за спойлер с укрепваща каишка съгласно отделна инструкция за **Plastic Spoiler Reinforcement Strap**.

**HR** Ako se plastični spojler nalazi na području gdje će se montirati gornje kuke, uvijek upotrebljavajte komplet za ojačanje spojlera koji sadrži traku za ojačanje, u skladu s uputama za **Plastic Spoiler Reinforcement Strap**.

**EL** Εάν η πλαστική αεροτομή είναι στην περιοχή που προορίζεται για τη στερέωση των επάνω αγκίστρων, να χρησιμοποιείτε πάντα το kit αεροτομής με τον μόνιμο ενίσχυσης, σύμφωνα με τις ξεχωριστές οδηγίες για **Plastic Spoiler Reinforcement Strap**.

**TR** Üst kancaların takıldığı alanda plastik rüzgarlık olması durumunda, rüzgarlık kitini her zaman ayrı bir talimat olan, **Plastic Spoiler Reinforcement Strap** talimatına uygun olarak destek - takviye kayısıyla birlikte kullanın.

**MT** Jekk l-ispoiler tal-plastik qiegħed fil-parti fejn se jiġu armati l-ganċijiet ta' fuq, dejjem uża l-kitt tal-ispoiler biċ-ċinga tar-rinfurzar, skont l-Istruzzjoni separata għaċ-**Plastic Spoiler Reinforcement Strap**.

**HE** אם ספויילר הפלסטיק נמצא באזור שבו יותקנו המתלים העליונים, יש להשתמש תמיד בערכת הספויילר עם רצועת החיזוק, בהתאם להוראות נפרדות עבור **Plastic Spoiler Reinforcement Strap**.

**AR** إذا كان الكليج البلاستيكي موجودًا في منطقة سيتم تركيب خطاطيف علوية، فحرص دائمًا على استخدام مجموعة الكليج مع حزام دعم وفقًا للتعليمات المنفصلة **Plastic Spoiler Reinforcement Strap**.

**ZH (CN)** 如果塑料扰流板位于将要安装上部挂钩的区域，请务必按照**Plastic Spoiler Reinforcement Strap**的单独说明，使用带有加固带的扰流板套件。

**ZH (TW)** 如果塑膠擾流板位於上方掛鉤將安裝的位置，請務必按照**Plastic Spoiler Reinforcement Strap**的個別說明，搭配強化綁帶使用擾流板套件。

**JA** プラスチック スポイラーが、上部フックが取り付けられる場所にある場合、別紙の**Plastic Spoiler Reinforcement Strap**用説明書に従って、強化ストラップ付きのスポイラーキットを常に使用してください。

**KO** 플라스틱 스포일러가 상단 고리나 장착될 곳에 있는 경우, 항상 **Plastic Spoiler Reinforcement Strap**를 위한 별도 지침에 따라 보강 벨트와 스포일러 키트를 사용하십시오.

**TH** หากสปอยเลอร์พลาสติกอยู่ในบริเวณที่จะติดตั้งของเกียด้านบน ให้ใช้ชุดสไปลเลอร์กับสายรัดเสริมตามคำแนะนำแยกต่างหากสำหรับ **Plastic Spoiler Reinforcement Strap**

**MS** Jika spoiler plastik berada di kawasan yang cangkuk atas akan dipasang, sentiasa gunakan kit spoiler dengan tali pengukuh, menurut arahan berasingan untuk **Plastic Spoiler Reinforcement Strap**

**i**

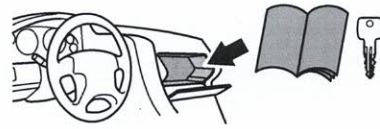
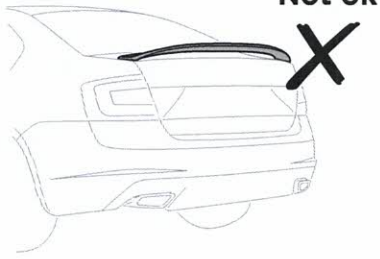

8,3 kg  
18,3 lbs

**Max 30 kg  
66 lbs**

Max 15 kg  
33 lbs

Max 15 kg  
33 lbs

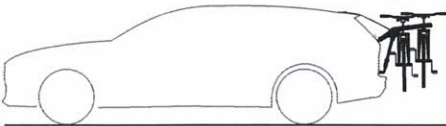

8,9 kg  
19,6 lbs

**Max 45 kg  
100 lbs**

Max 15 kg  
33 lbs

Max 15 kg  
33 lbs

Max 15 kg  
33 lbs

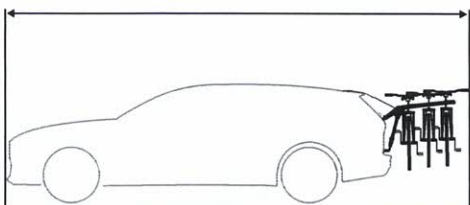
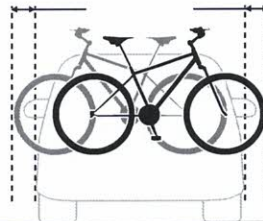
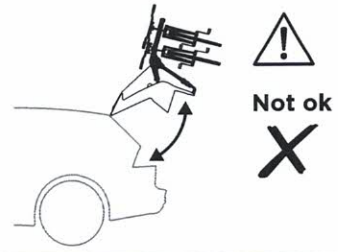
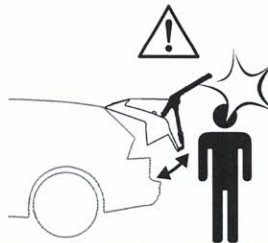
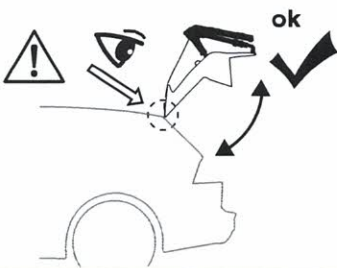
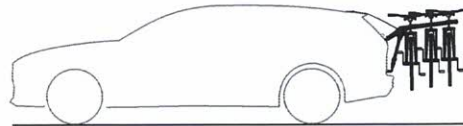

1

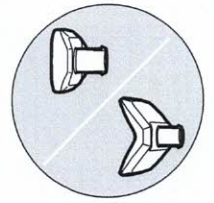
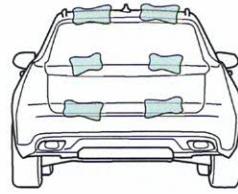
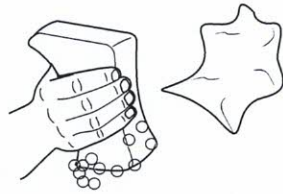

2

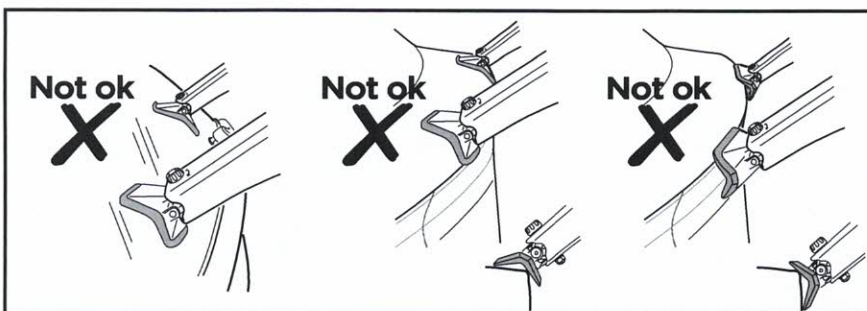
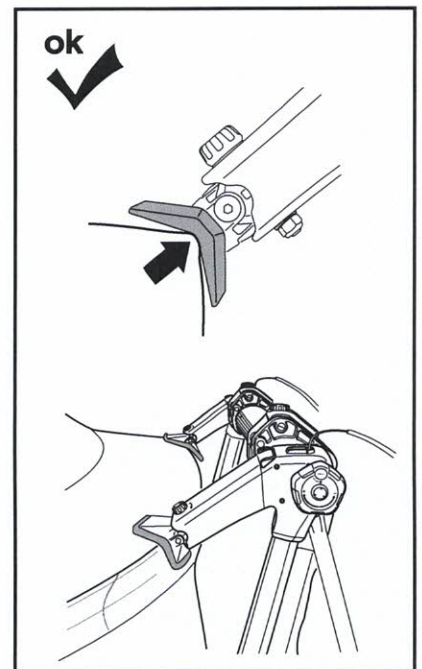
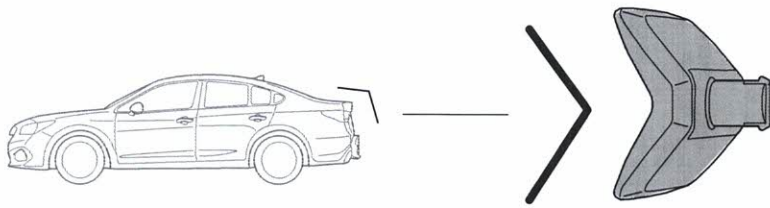
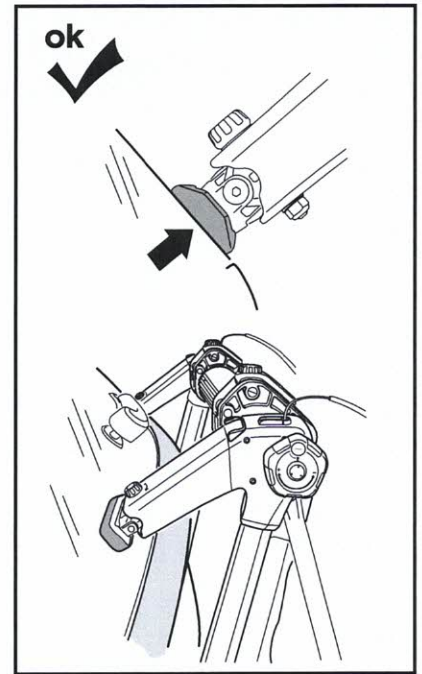
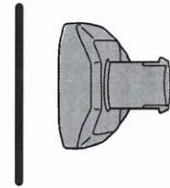
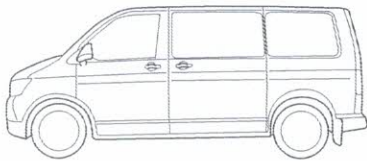

3

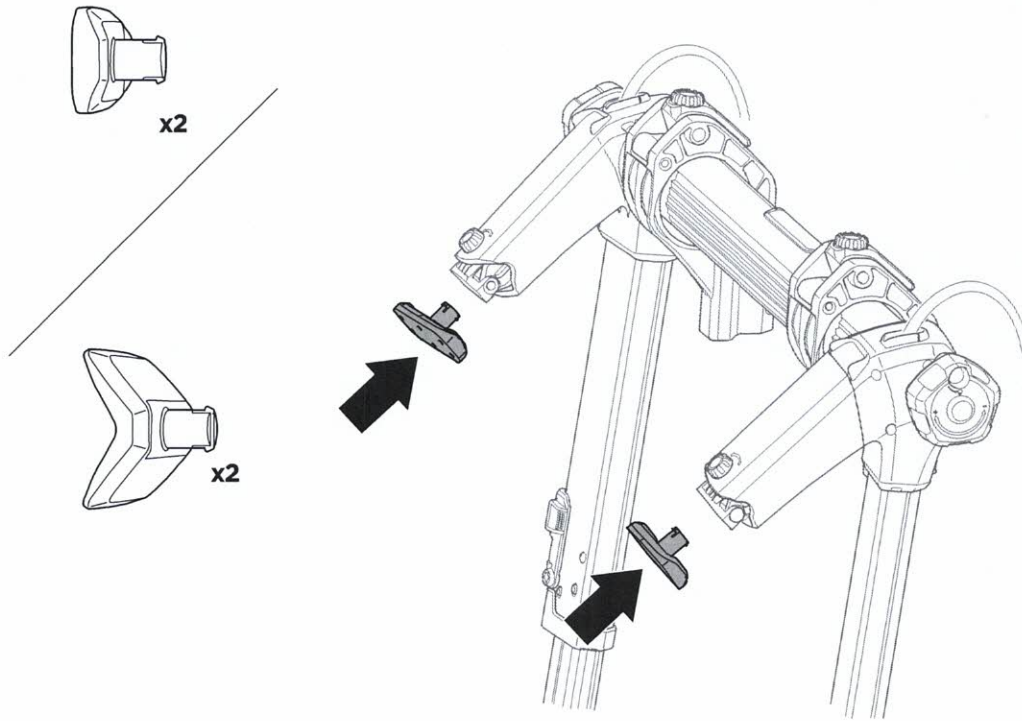

4

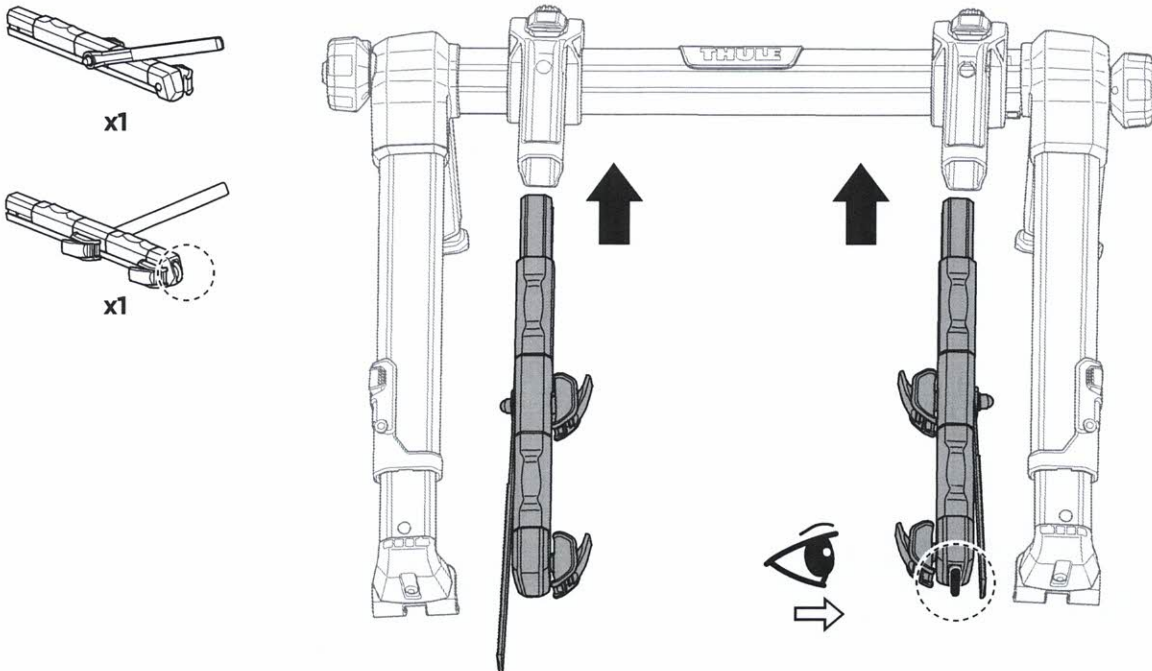

# 5

x2

x2

x2

x2

x1

x1

x4(6)

x2

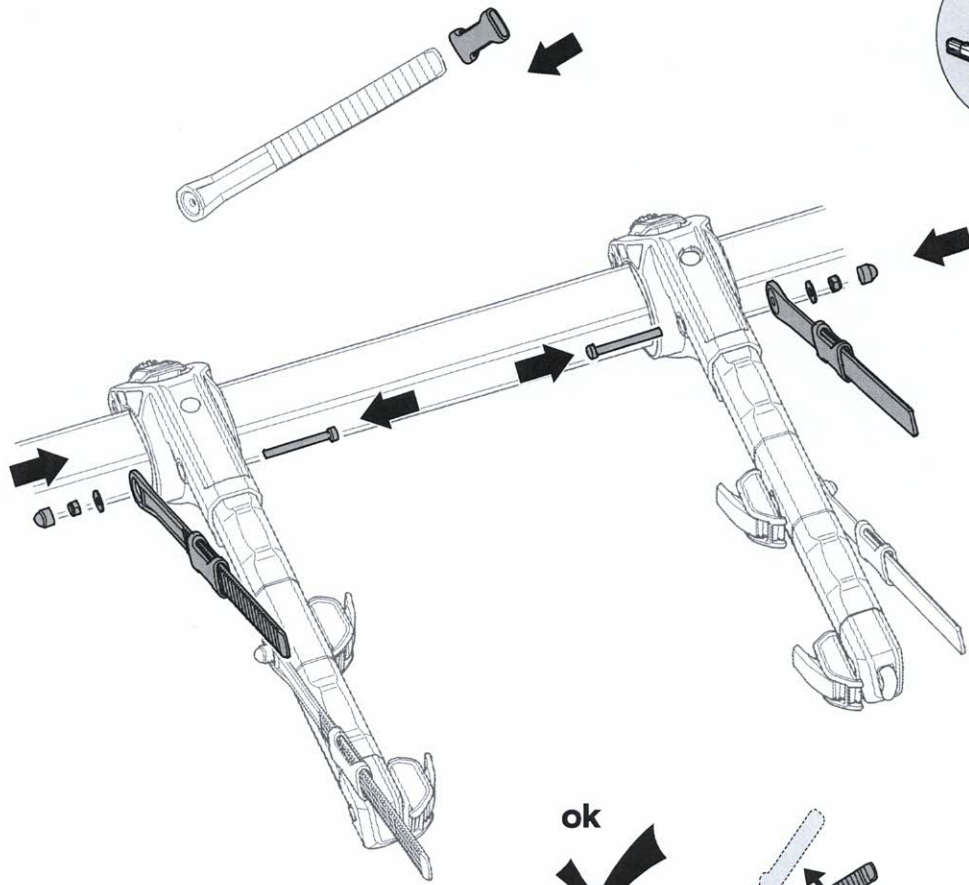

ok

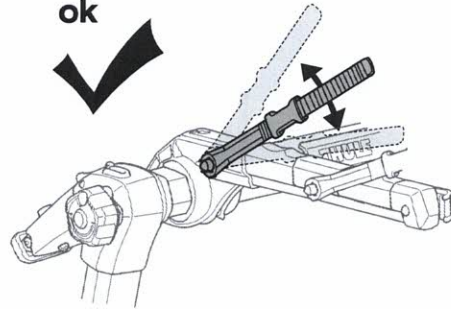

# 6

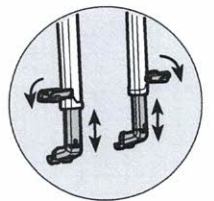
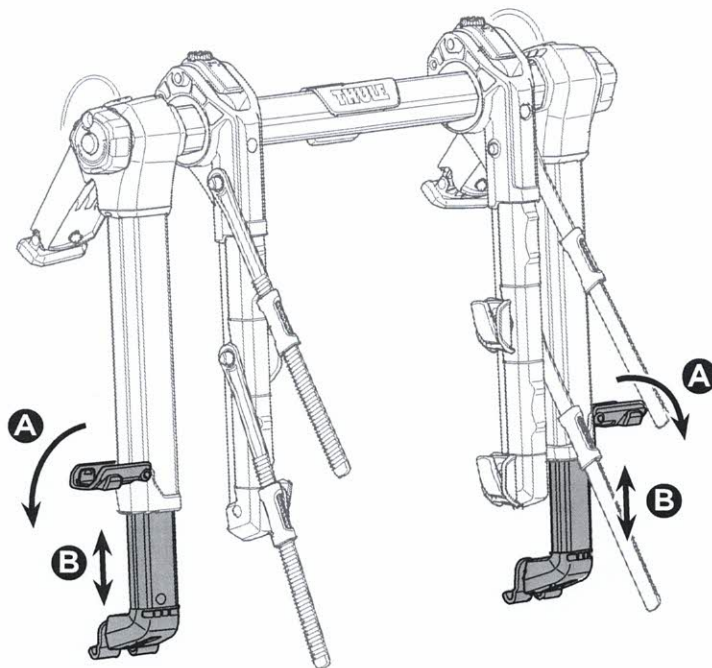



7

A

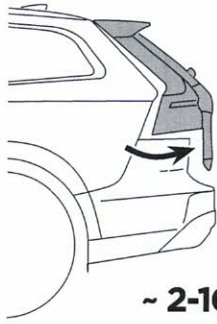

~ 2-10 cm  
~ 1-4 "

B

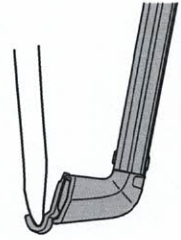
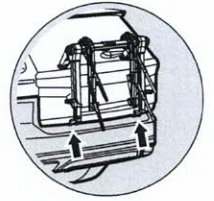
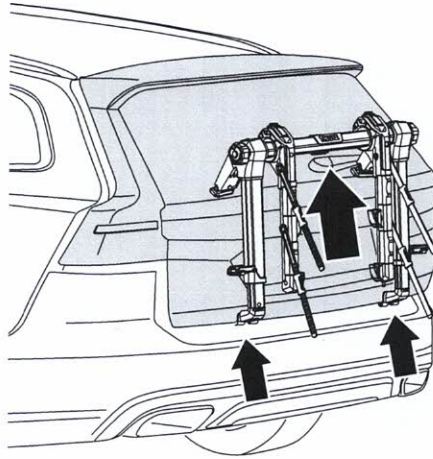

C

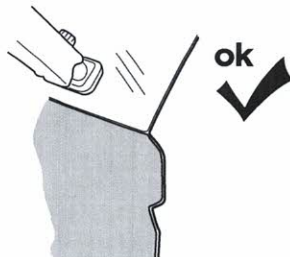
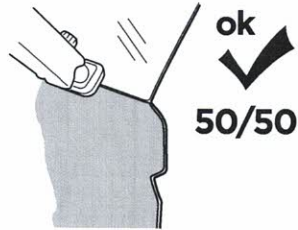
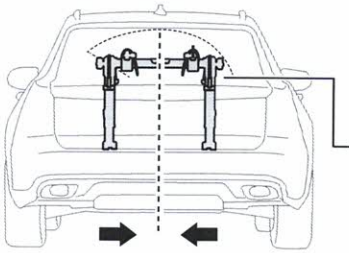

D

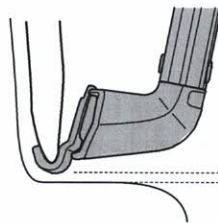
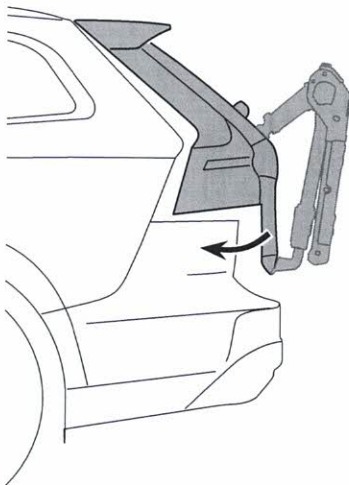

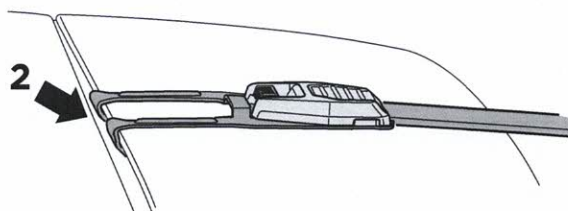
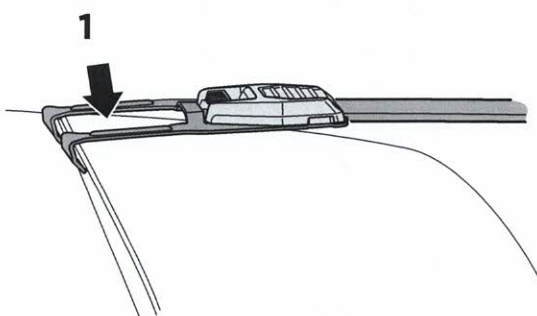
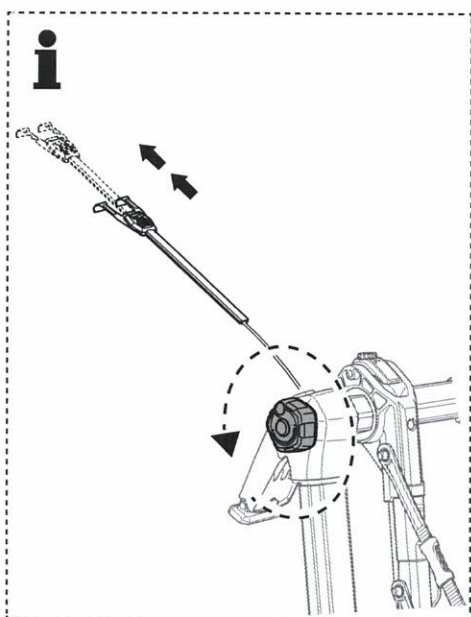
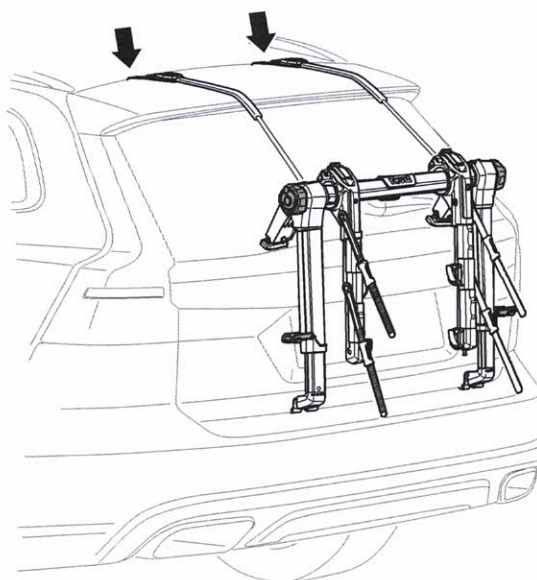
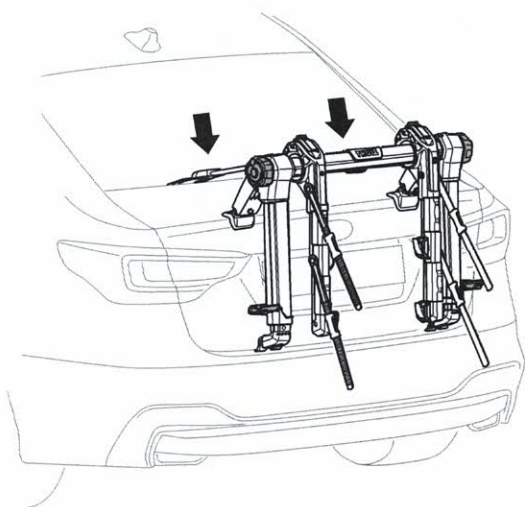
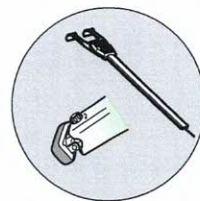
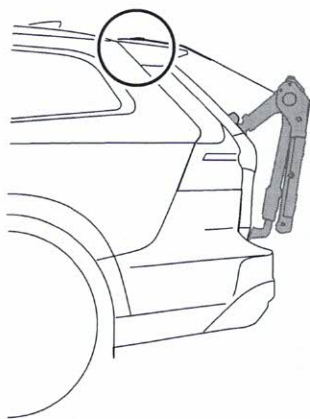

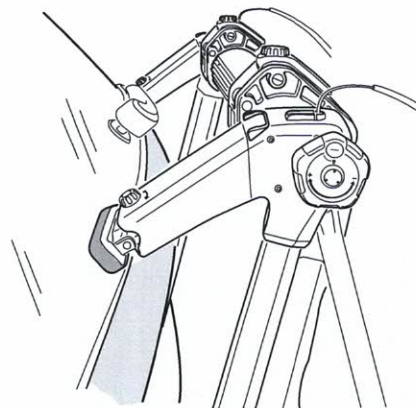
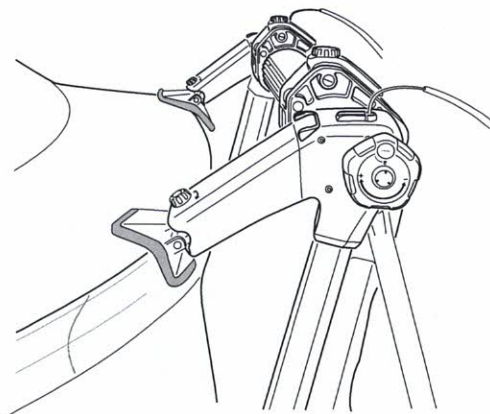
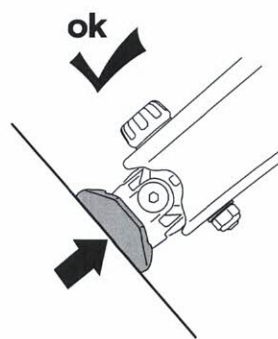
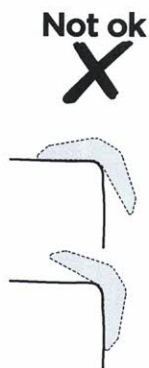
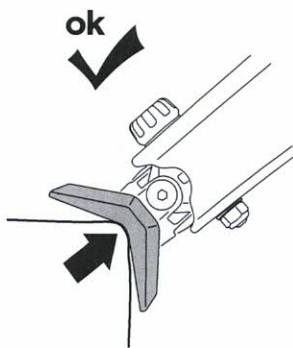
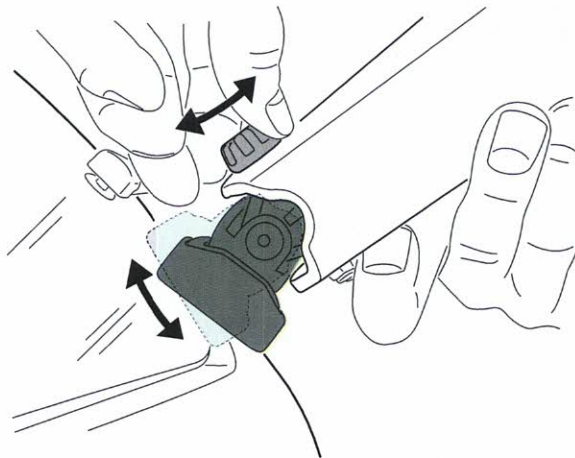
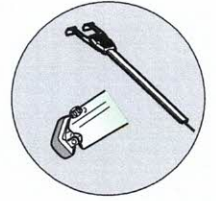
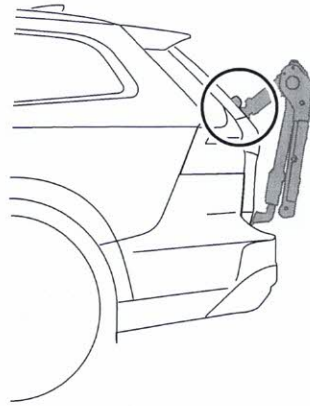

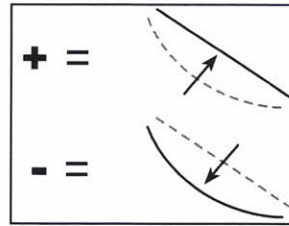
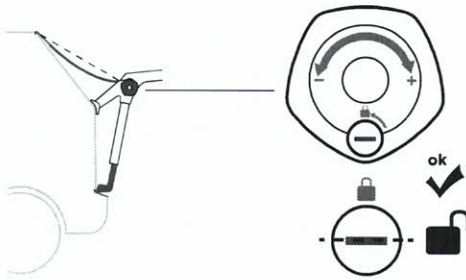

- EN** The first installation requires many rotations on the knob  
**FR** La première installation nécessite plusieurs rotations de la molette  
**ES** La primera instalación requiere girar el pomo muchas veces.  
**DE** Bei der Erstinstallation muss der Knopf einige Male gedreht werden.  
**NL** Bij de eerste installatie moet u lang draaien aan de knop.  
**PT** A primeira instalação requer muitos giros no botão .  
**IT** La prima installazione richiede molte rotazioni del pomello.  
**SV** Den första installationen kräver många varvs vridning på ratten.  
**DK** Den første montering kræver mange omdrejninger på knappen.  
**NO** Den første installasjonen krever mange rotasjoner på knotten.  
**FI** Ensimmäinen asennus vaatii nupin kiertämistä useaan kertaan.  
**IS** Fyrsta uppsetningin krefst margra snúninga á hnúðnum.  
**ET** Esimest korda paigaldades tuleb nuppu keerata mitu korda.  
**LV** Pirmajā uzstādīšanās reizē poga ir jāgriež vairākas reizes.  
**LT** Montuojant pirmą kartą, rankenėlę reikia sukti daug kartų.  
**RU** При первой установке потребуется много раз повернуть ручку.  
**UK** Під час першого встановлення вимагається виконання багатьох обертань ручки.  
**PL** Pierwszy montaż wymaga wielu obrotów pokręcia.

- CS** Při první montáži je potřeba vícekrát otočit rúžici.  
**HU** Az első felszereléshez sokszor kell forgatni a gombot.  
**RO** Prima instalare necesită mai multe rotiri ale mânerului.  
**SK** Pri prvej inštalácii je potrebných veľa otočení kľuky.  
**SL** Pri prvi namestitvi je potrebnih precej zasukov gumba.  
**BG** Първото монтиране изисква много завъртания на копчето.  
**HR** Pri prvom postavljanju gumb treba dosta okretati.  
**EL** Κατά την πρώτη εγκατάσταση, απαιτούνται πολλές περιστροφές του κουμπιού.  
**TR** İlk kurulumda topuzu birçok kez döndürmek gerekir.  
**MT** L-ewwel installazzjoni tirrikjedji li l-pum jiddawwar għal hafna drabi.

**HE** בהתקנה הראשונה יש לסובב את הידית פעמים רבות.

**AR** يتطلب أول تثبيت لف المقبض عدة مرات.

**ZH (CN)** 首次安装需要多次旋转旋钮。

**ZH (TW)** 首次安装需要多次旋轉旋鈕。

**JA** 初めて取り付ける場合は、ノブを何回も回転させる必要があります

**KO** 첫 설치 시에는 손잡이를 많이 회전시켜야 합니다.

**TH** การติดตั้งครั้งแรกต้องมีการหมุนลูกบิดหลายครั้ง.

**MS** Pemasangan pertama memerlukan banyak pemutaran tombol.

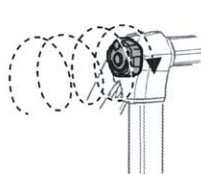

10-20 s

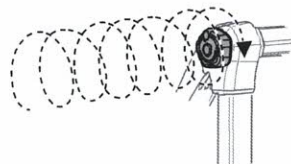

40-60 s

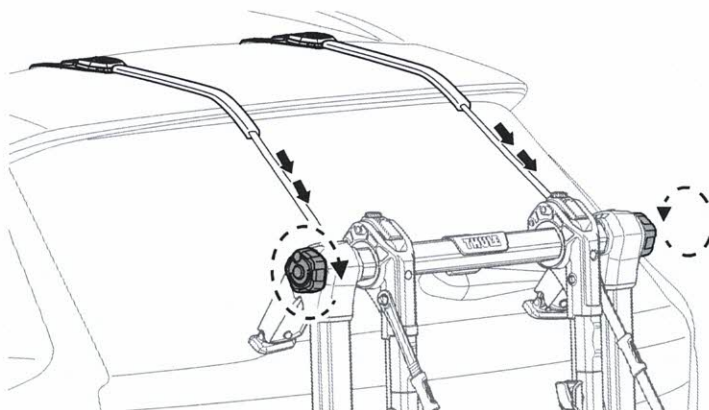

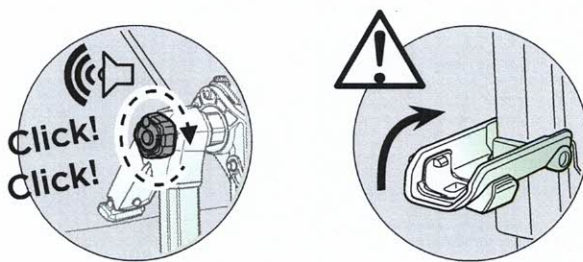

- EN** After hearing repeated "CLICK" close the hatch.  
**FR** Après avoir entendu plusieurs déclics, fermez la trappe.  
**ES** Después de escuchar varios clics, cierre la escotilla.  
**DE** Wenn Sie wiederholt ein „KLIKK“-Geräusch hören, schließen Sie die Klappe.  
**NL** Nadat u meerdere keren een "KLIK"-geluid hoort, sluit u.  
**PT** Após ouvir o "CLIQUE" repetido, feche a escotilha.  
**IT** Dopo aver sentito ripetuti "CLIC", chiudere il portello.  
**SV** Efter att upprepade "KLICK" hörs, stäng luckan.  
**DK** Efter du hører et gentaget "KLIK", luk lugen.  
**NO** Etter å ha hørt gjentatt "KLIKK", lukker du liken.  
**FI** Sulje taso, kun kuulet toistuvan napsahduksen.  
**IS** Eftir að endurteknið „SMELLIR“ heyrast skal loka stigi.  
**ET** Pärast korduvaid klõpse tuleb sulgeda tase.  
**LV** Pēc tam, kad vairākas reizes ir atskanējis "KLIKŠKĪS", fiksējiet līmeni.  
**LT** Išgirdę kelis spragtelėjimus, uždarykite svirtį.  
**RU** Услышав повторные щелчки, закройте рычаг.  
**UK** Коли ви почуєте повторюваний звук "КЛАЦАННЯ", закрийте важіль.  
**PL** Po usłyszeniu powtórnego kliknięcia zamknąć poziom.

- CS** Jakmile opakovaně uslyšíte zaklapnutí, uzavřete danou pozici.  
**HU** Többször is „KATT” hang után rögzítse a kart.  
**RO** După ce auziți "CLIC" în mod repetat, închideți nivelul.  
**SK** Keď sa opakovane ozve cvaknutie, zatvorte páčku.  
**SL** Potem ko večkrat slišite zvok »KLIK«, zaprite raven.  
**BG** След като чуете многократно щракване, затворете нивото.  
**HR** Nakon što začujete ponavljajući zvuk „KLIKA” zatvorite razinu.  
**EL** Μόλις ακούσετε επανειλημμένα τον χαρακτηριστικό ήχο "ΚΛΙΚ" κλείστε την επιφάνεια.  
**TR** Tekrarlayan "KLIK" seslerini duyduktan sonra düzeneği kilitleyin.  
**MT** Wara li tisma' "KLIKK" b' mod ripetut, aghlaq l-invell.

**HE** לאחר שישמעו כמה "קליקים" יש לסגור את המשטח.  
**AR** بعد سماع "نقرة" متكررة ميزان التسوية.

- ZH (CN)** 听到重复的“咔嚓”声后，关闭水准仪。  
**ZH (TW)** 聽到多次「喀答聲」後，關上。  
**JA** 繰り返し「カチっとする音」を聞いたら、レベルを閉じてください。  
**KO** 반복된 "찰라" 소리가 들리면 레벨을 닫습니다.  
**TH** หลังจากได้ยินเสียง "คลิก" ซ้ำ ให้ปิดระดับ.  
**MS** Selepas mendengar bunyi "KLIK" berulang kali, tutup paras.

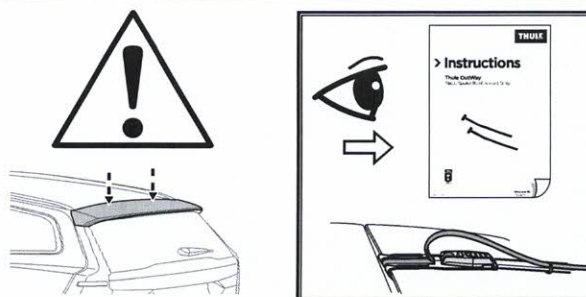
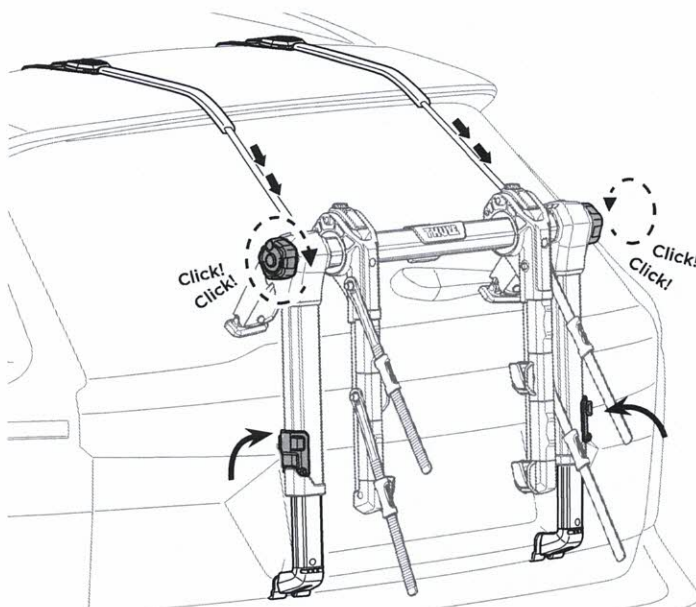
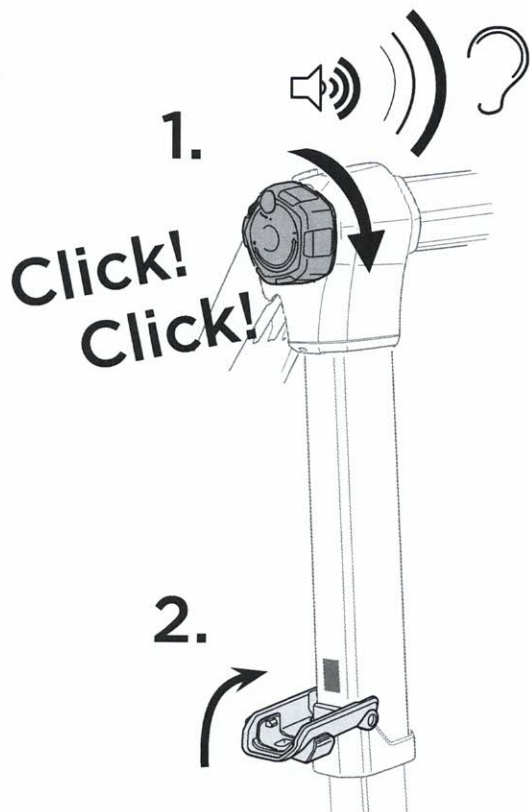

12

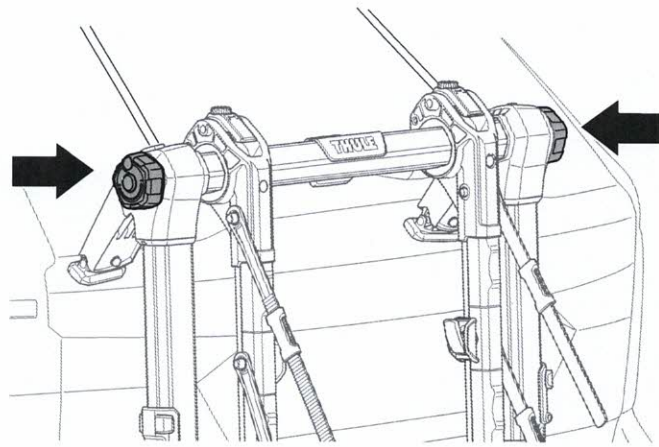

13

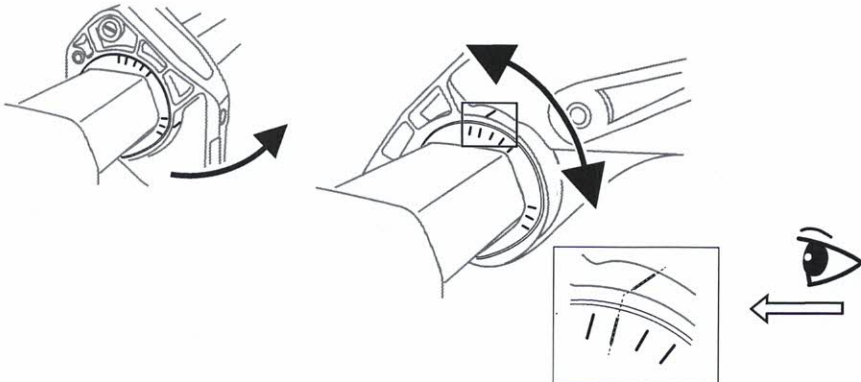
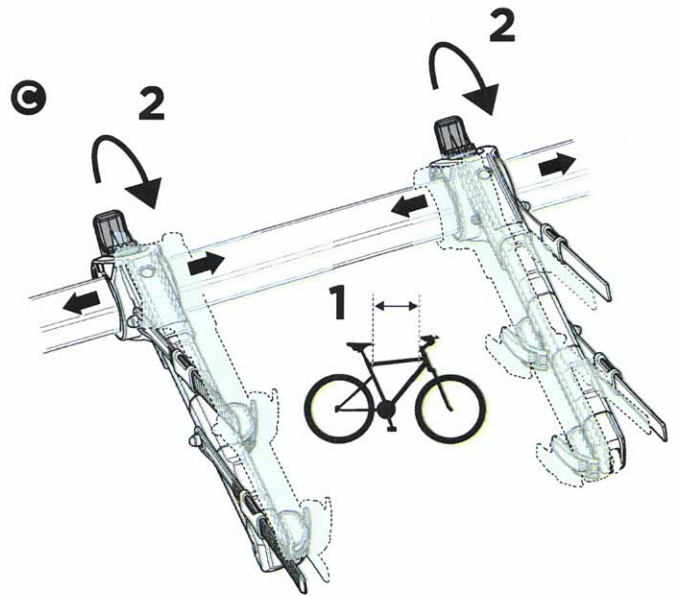
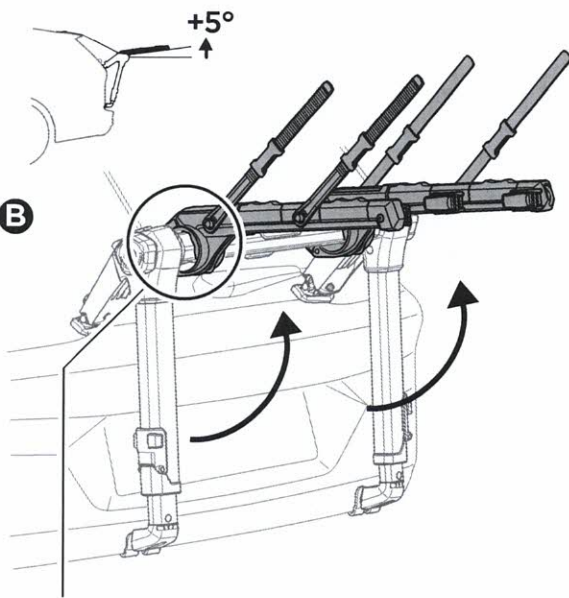
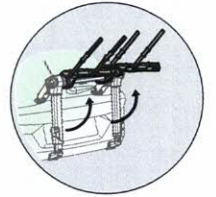
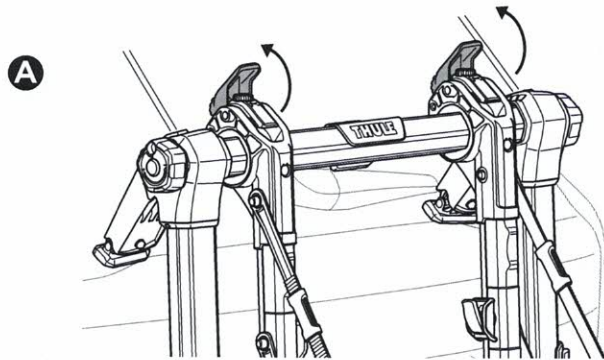

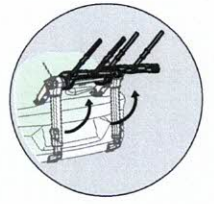

Not ok

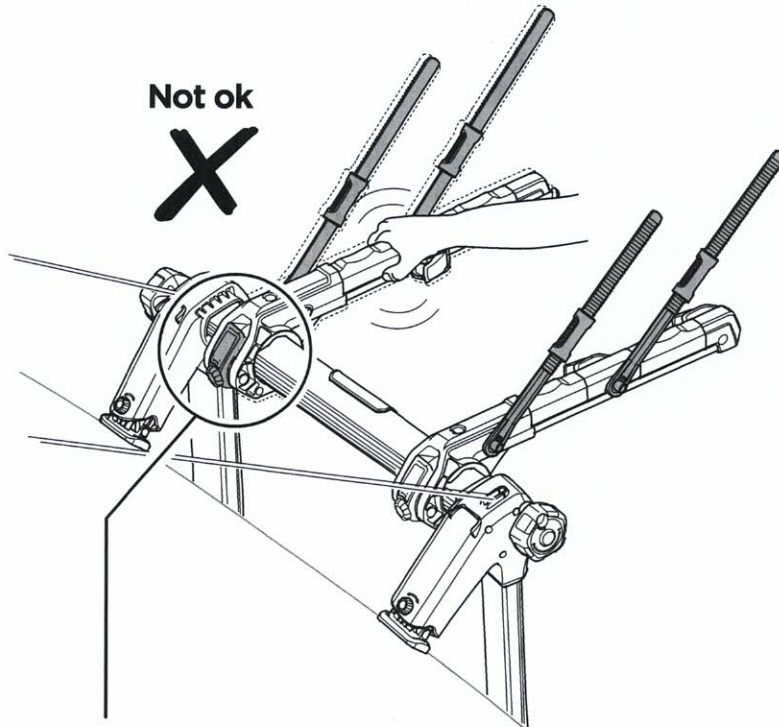

1

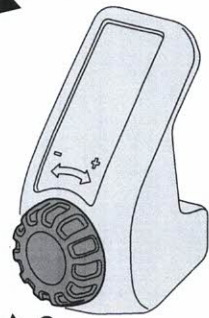

3

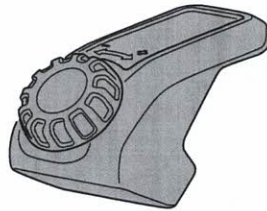

ok

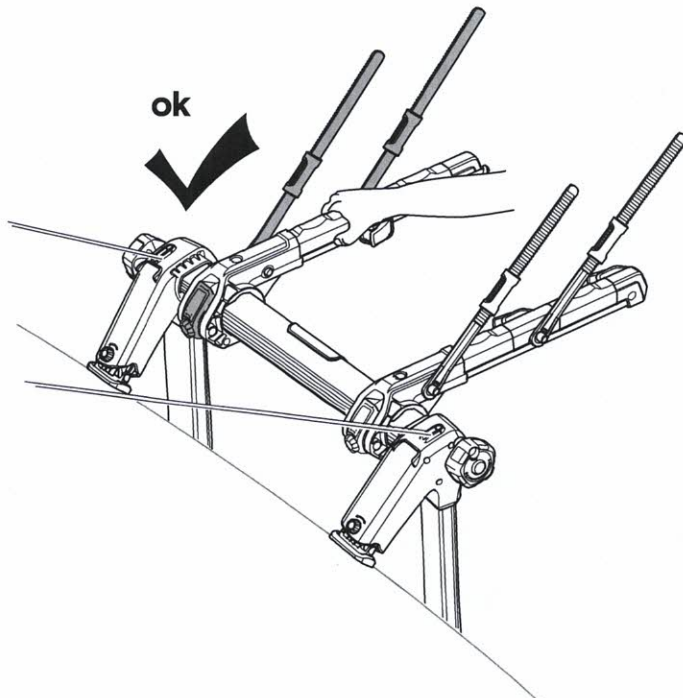



**i**

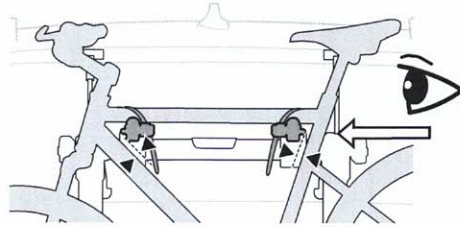

Min 10 mm/0,4''

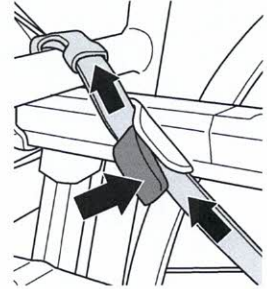

**A**

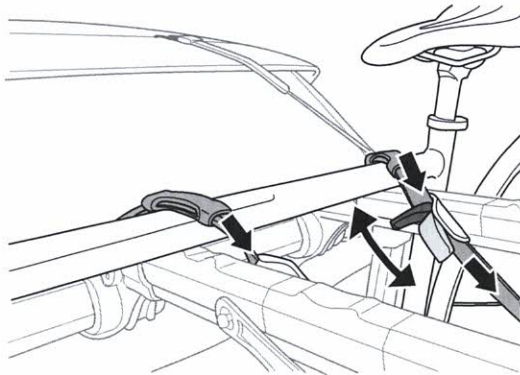

**B**

**Not ok**

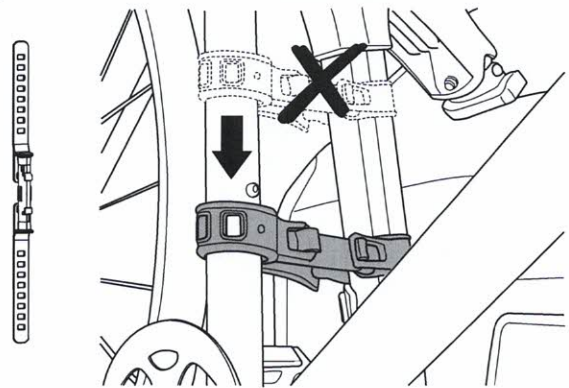

**C**

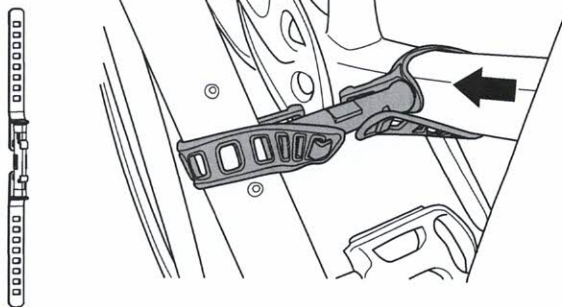

**D**

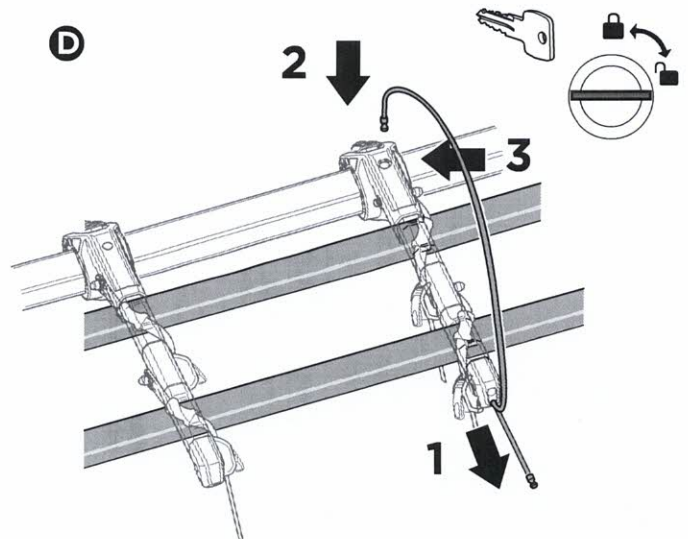



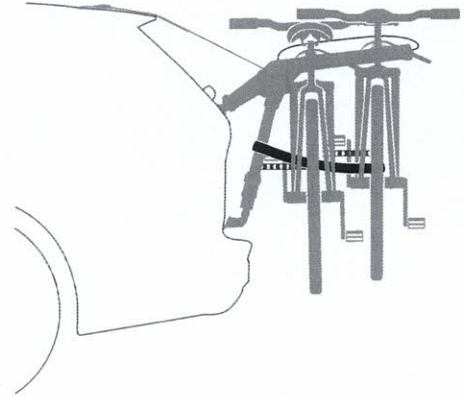
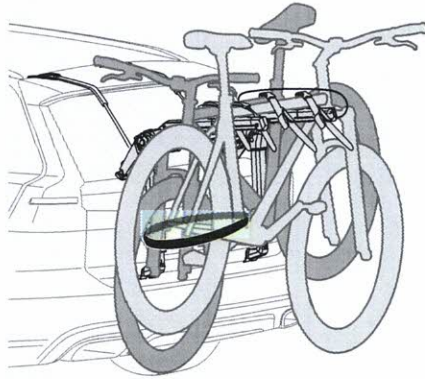

**i**

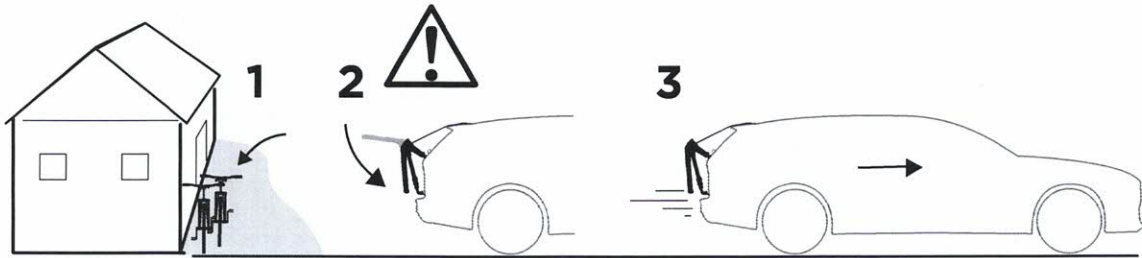

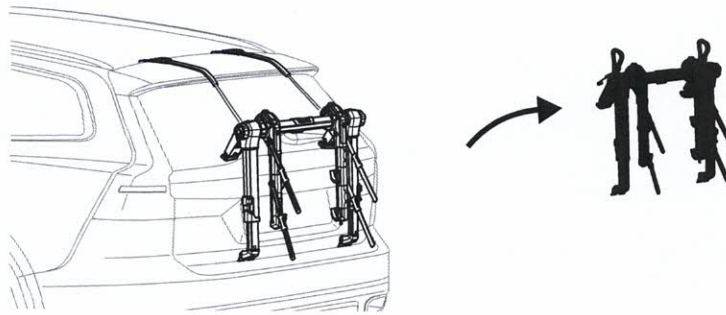

**A**

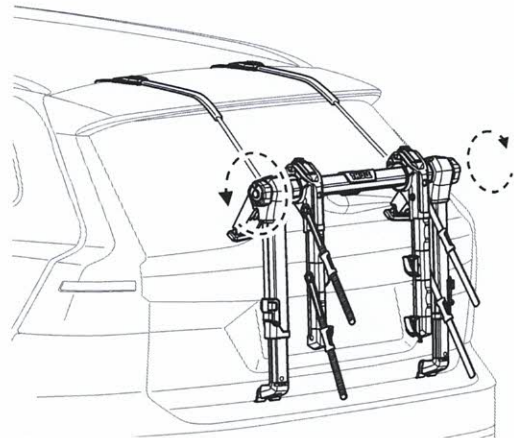
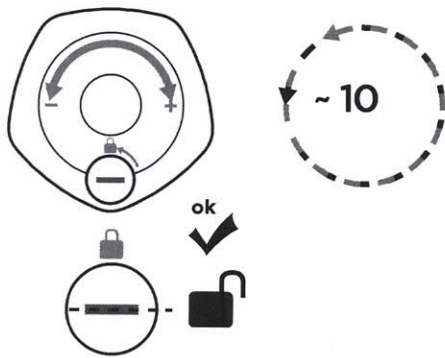

**B**

1

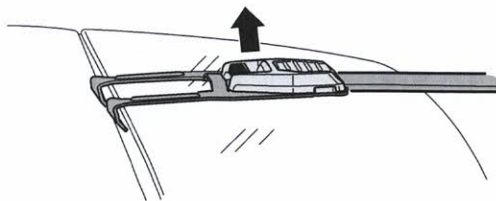

2

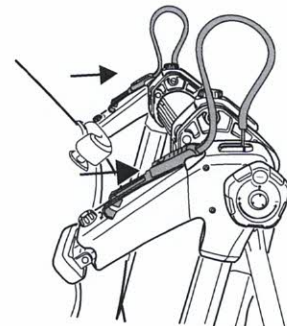

**C**

1

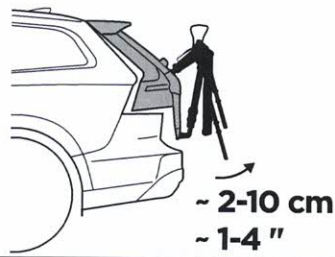

2



3

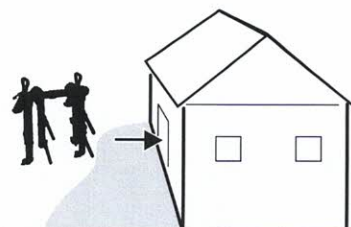

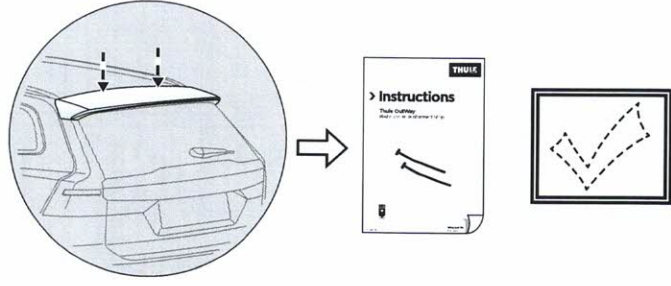
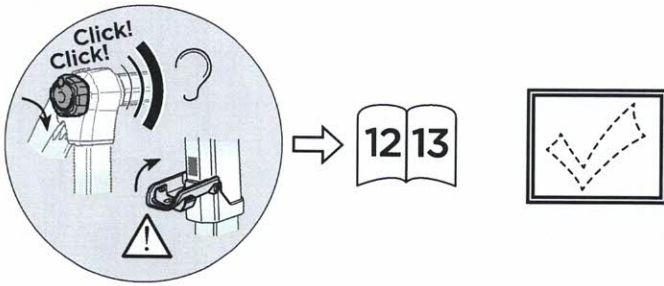
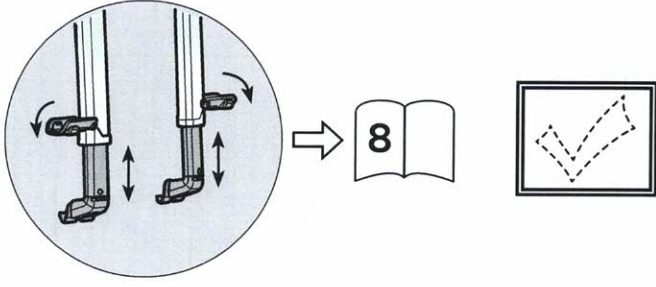
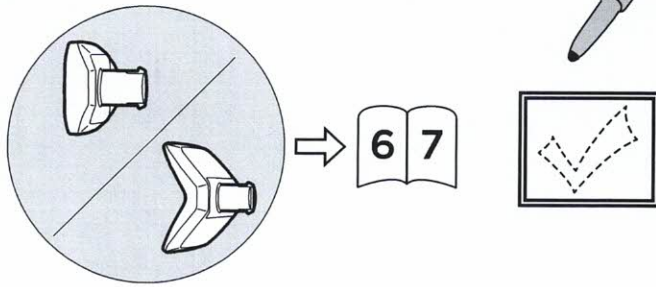

EN Accessories  
 FR Accessoires  
 ES Accesorios  
 DE Zubehör  
 NL Accessoires  
 PT Acessórios  
 IT Accessori  
 SV Tillbehör  
 DK Tilbehør

NO Tilbehør  
 FI Lisävarusteet  
 IS Aukabúnaður  
 ET Lisavarustus  
 LV Piederumi  
 LT Priedai  
 RU Аксессуары  
 UK Аксесуари  
 PL Akcesoria

CS Doplnky  
 HU Tartozékok  
 RO Accesorii  
 SK Príslušenstvo  
 SL Dodatki  
 BG Принадлежности  
 HR Dodaci  
 EL Εξαρτήματα  
 TR Aksesuarlar

MT Aċċessorji  
 אביזרים HE  
 ملحقات AR  
 ZH (CN) 附件  
 ZH (TW) 配件  
 JA アクセサリー  
 KO 액세서리  
 TH อุปกรณ์เสริม  
 MS Aksesori

## Thule One-Key System



450400 (x4)  
 450600 (x6)  
 450800 (x8)  
 \* 451200 (x12)  
 \* 451600 (x16)

### Thule Bike Frame Adapter 982

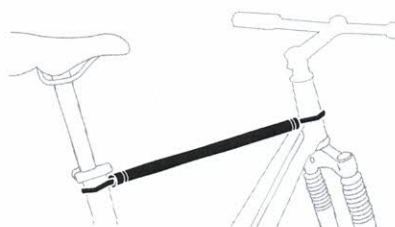

### \* Thule Wall Hanger 9771



### \* Thule 3rd Brake Light 9904

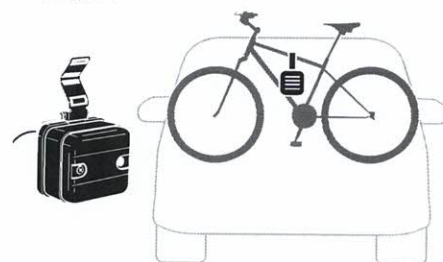

### \* Thule Light Board 976

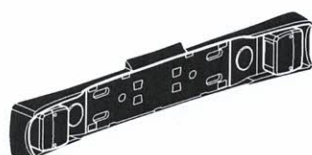

### Thule Bike Protector 988



\* Only available in select markets

Thule Sweden AB, Borggatan 5  
335 73 Hillerstorp, SWEDEN

» PART OF THULE GROUP

info@thule.com

© Thule Group 2020. All rights reserved.

www.thule.com

5560116001